

GS EVO 25S4 1800X525

Professional hand pallet truck (2.500 kg)



GS EVO

GS EVO is the best choice for hand pallet trucks, designed for intensive use with maximum ease of use and superior ergonomics. Available in a wide range of configurations, it is the right tool for the customer who is looking for a product tailored to their application or simply a great professional tool.



HYDRAULIC GROUP

The GS EVO hydraulic unit has been designed with extreme attention to detail to have superior characteristics, such as:

- **MONOLITHIC DESIGN:** the pump body, with integrated oil tank, in resistant and reliable cast iron protects all components avoiding accidental damage. The casting processing is performed by numerically controlled machines to achieve high precision and accuracy tolerances.
- **CHROME PLATED PISTON STEM and OIL SEAL:** for greater resistance to corrosion and to prevent oil leaks during use.
- **MAXIMUM PRESSURE VALVE:** safety device that protects the operator and pallet truck from overloads.
- **PROPORTIONAL CONTROL VALVE:** the lowering speed of the forks is proportional to the pressure exerted on the lever by the operator. Perfect work tool for carrying fragile and delicate loads such as crystal, glass and ceramics.



STANDARD CONFIGURATION

- Directional wheels in polyurethane
- Polyurethane loading rollers

They guarantee silence, smoothness and are non-marking

- Infeed / outfeed rollers. Additional rollers to facilitate entry and exit from the pallet equipped with lower slats, reducing the impact on the main rollers and ensuring a longer life

- 3D ergonomic wheelhouse. The wheelhouse has a special 3D design, which guarantees better ergonomics. Compared to a conventional drawbar, this shape allows the operator to have an optimal position when pushing the load, increasing efficiency and reducing effort. This is thanks to two large lateral grip areas specially angled to have a correct posture of arms and wrists during the operation of the trolley

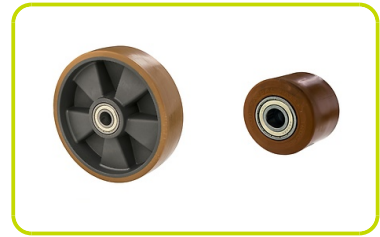

PAINTING

All metal parts, after an appropriate washing and degreasing operation, are painted with polyester powder at a temperature of 250 ° to ensure maximum resistance to wear and atmospheric agents.



EASY INSTALLATION

Easy and quick to install wheelhouse. The wheelhouse / pump connection via two fully welded joints that guarantee superior strength in the most difficult applications.



OPTIONAL AVAILBLE

- Directional wheels in different materials: rubber, aluminum / polyurethane, nylon
- Quicklift (quick lift). The perfect tool for lifting your loads quickly. Save time and improve efficiency with the specially designed hydraulic pump. Only two strokes to lift loads up to 120 kg or three pumps for loads over 120 kg, compared to 5 strokes required with a non-quicklift pallet truck
- Covered rudder. The plastic coating guarantees operator comfort thanks to a lower heat exchange and helps to reduce vibrations allowing a more comfortable and safe grip
- Manually operated brake. The pallet truck brake acts by means of two drum brakes on the directional wheels which can be in rubber or polyurethane and can be activated using the dedicated lever on the drawbar. It guarantees a stable and movement-free positioning of the pallet truck during parking



COMPLETE RANGE OF VARIATIONS (See dedicated GS EVO product sheets)

- Capacity 30 quintals. Version with reinforced structure for any fork size



- Silent version certified by Piek. Designed to strongly reduce noise emission even on the worst surfaces, this option is suitable for use in deliveries in residential areas and supermarkets



- Low profile forks. Required where the pallet has limited access due to height. GS EVO can have a low profile with a ground clearance of only 55mm

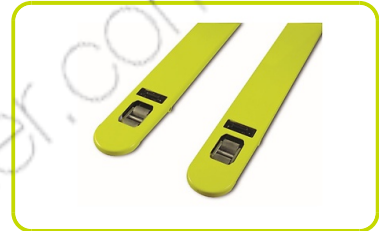

- INOX / Galvanized version. Ideal tool for handling loads in wet conditions. Suitable for environments where high hygiene standards are applied, such as the chemical, pharmaceutical or food industry



Descrizione

| | | |
|---|------|-----------------|
| 1.1 Costruttore | | PR INDUSTRIAL |
| 1.3 Tipo di Propulsione | | Manuale |
| 1.4 Sistema di guida | | Accompagnamento |
| 1.5 Portata | Q Kg | 2500 |
| 1.6 Baricentro | c mm | 900 |
| 1.8 Distanza asse ruote di carico da base forca | x mm | 1582 |
| 1.9 Passo | y mm | 1842 |

Pesi

| | | |
|---|----|------|
| 2.1 Massa in servizio | Kg | 129 |
| 2.2 Carico asse posteriore (pieno carico) | Kg | 1628 |
| 2.2 Carico asse anteriore (pieno carico) | Kg | 1001 |
| 2.3 Carico asse posteriore (senza carico) | Kg | 54 |
| 2.3 Carico asse anteriore (senza carico) | Kg | 75 |

Telaio/Ruote

| | | |
|--|--------|-------------------|
| 3.1 Gommatura, anteriore | | POLY.I./ NYLON |
| 3.1 Gommatura posteriore | | POLY |
| 3.2 Dimensione ruote anteriori - Diametro | mm | 200 |
| 3.2 Dimensione ruote anteriori - Larghezza | mm | 45 |
| 3.3 Dimensione ruote posteriori - Diametro | mm | 82 |
| 3.3 Dimensione ruote posteriori - Larghezza | mm | 60 |
| 3.5 Dimensioni ruote posteriori - Q.tà (x=motrice) | nr | 4 |
| 3.5 Dimensioni ruote anteriori - Q.tà (x=motrice) | nr | 2 |
| 3.6 Carreggiata anteriore | b10 mm | 155 |
| 3.7 Carreggiata posteriore | b11 mm | 375 |

Dimensioni

| | | |
|---|--------|------|
| 4.4 Altezza di sollevamento | h3 mm | 115 |
| 4.9 Altezza del timone in posizione di guida max | h14 mm | 1185 |
| 4.9 Altezza del timone in posizione di guida min | h14 mm | 710 |
| 4.15 Altezza forche abbassate | h13 mm | 85 |
| 4.19 Lunghezza totale | l1 mm | 2200 |
| 4.20 Lunghezza unità motrice | l2 mm | 400 |
| 4.21 Larghezza totale | b1 mm | 525 |
| 4.22 Dimensioni forche - Spessore | s mm | 55 |
| 4.22 Dimensioni forche - Larghezza | e mm | 150 |
| 4.22 Lunghezza forche | l mm | 1800 |
| 4.25 Larghezza forche | b5 mm | 525 |
| 4.32 Luce libera a metà passo | m2 mm | 30 |
| 4.34 Corridoio di stivaggio per pallet 800x1200 longitudinalmente | Ast mm | 2673 |
| 4.35 Raggio di volta | Wa mm | 2017 |

Prestazioni

| | | |
|---|---------|------|
| 5.2 Velocità di sollevamento con carico | pompate | 12 |
| 5.2 Velocità di sollevamento senza carico | pompate | 12 |
| 5.3 Velocità di discesa con carico | m/s | 0.06 |

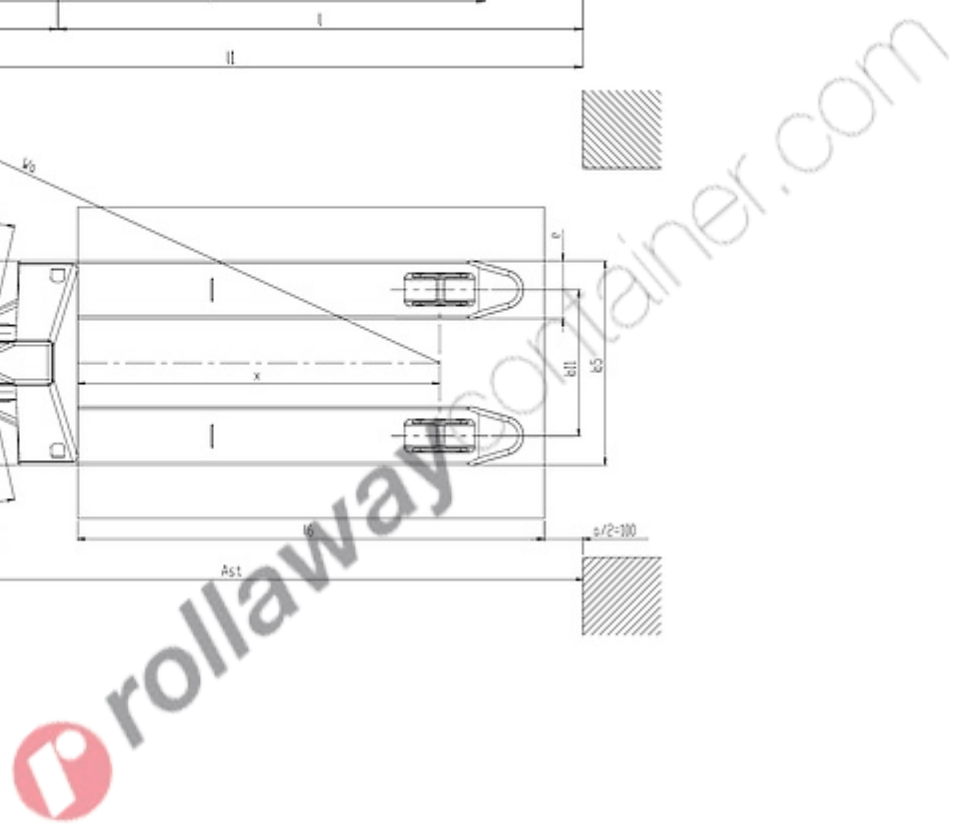
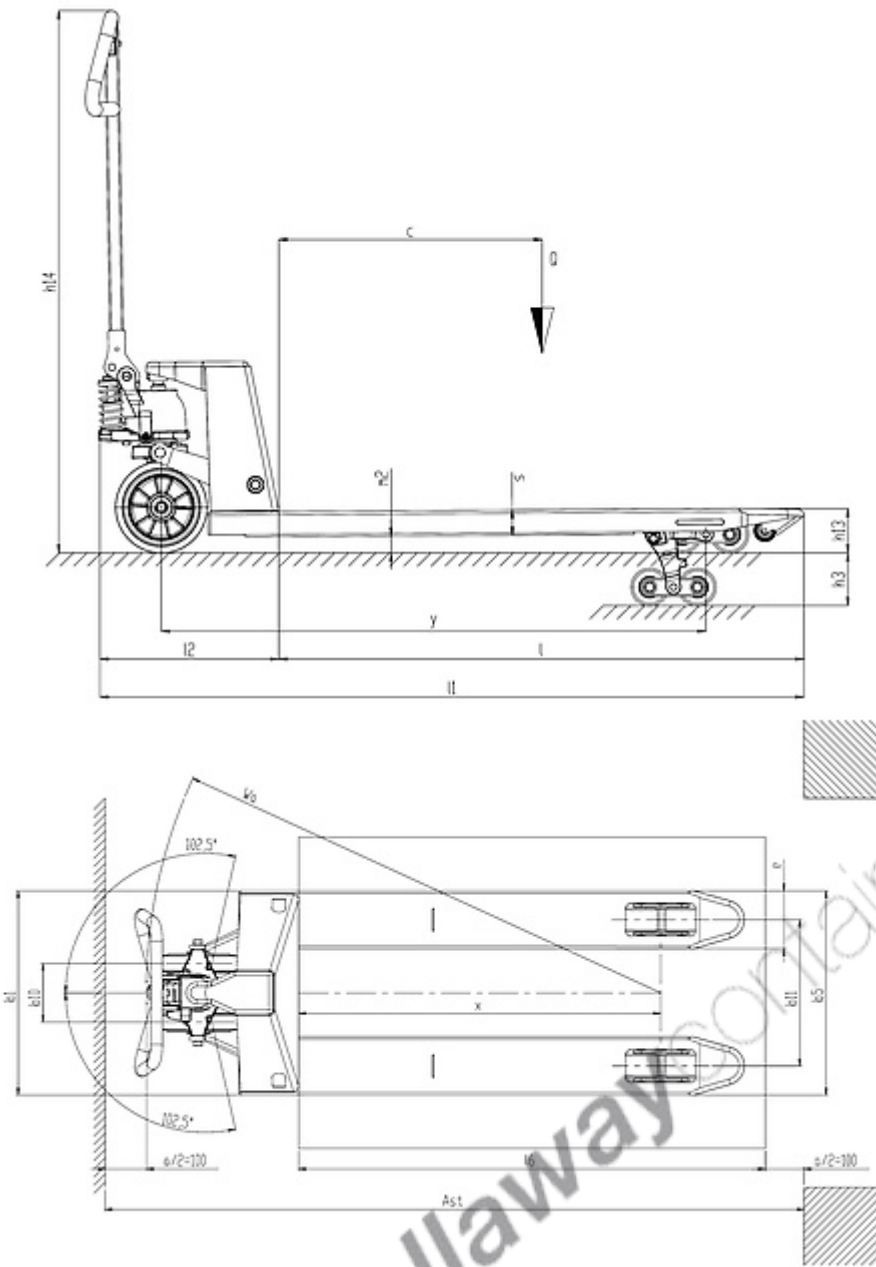

The information is aligned with the Data file at the time of download. Printed on 21/02/2022 (ID 12852)

©2022 | PR INDUSTRIAL s.r.l. | All rights reserved | Image shown may not reflect actual package. Specifications subject to change without notice

