



Robot - Mast

SFERA M
SFERA EASY M

Use and Maintenance Manual

Translation of the original

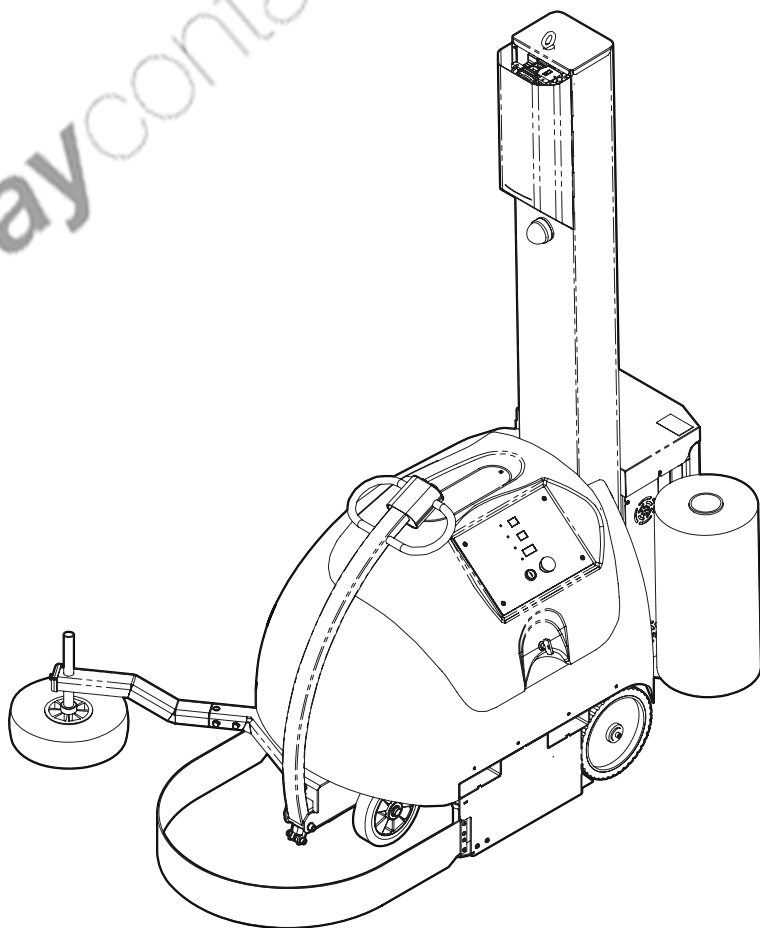

Atlanta Stretch S.p.A.

Via Torrianese, 58
47824 - Poggio Torriana - RN
ITALY

Tel. 0541 627145

www.atlantastretch.com

info@atlantastretch.com



EN

Rev.0 7/04/2021

 **rollaway**container.com

1	FOREWORD	3
1.1	HOW TO READ AND USE THE INSTRUCTIONS MANUAL.....	3
1.1.1	THE IMPORTANCE OF THE MANUAL.....	3
1.1.2	SAFE KEEPING THE MANUAL.....	3
1.1.3	CONSULTING THE MANUAL.....	3
1.1.4	COPYRIGHT.....	4
1.1.5	INFORMATION ON THE IMAGES AND CONTENTS.....	4
1.1.6	UPDATE OF THE INSTRUCTION MANUAL.....	4
1.1.7	SYMBOLS - MEANING AND USE.....	5
1.2	WHO THE MANUAL IS FOR.....	6
2	SAFETY	7
2.1	GENERAL SAFETY INSTRUCTIONS.....	7
2.2	SAFETY SIGNS.....	8
2.3	WARNINGS OF RESIDUAL RISKS.....	10
2.4	SAFETY DEVICES.....	11
2.5	PERSONAL PROTECTIVE EQUIPMENT (PPE).....	12
2.6	TECHNICAL ASSISTANCE.....	13
3	MACHINE DESCRIPTION	14
3.1	MANUFACTURER AND MACHINE IDENTIFICATION DATA.....	14
3.2	GENERAL DESCRIPTION.....	15
3.3	ROLL HOLDER CARRIAGES.....	20
3.3.1	OPTIONAL EQUIPMENT.....	26
3.3.1.1	AUTOMATIC CUT.....	26
3.3.1.2	STRIP CUT.....	27
3.3.1.3	STRIP TIGHTENER (MANUAL VERSION).....	29
3.3.1.4	STRIP TIGHTENER (AUTOMATIC VERSION).....	30
3.3.1.5	MESH ROLLER.....	33
3.3.1.6	FILM WEIGHING.....	34
3.4	INTENDED USE - PROPER USE - PURPOSE.....	35
3.5	UNINTENDED AND UNAUTHORISED USE - FORESEEABLE AND	

	UNFORESEEABLE IMPROPER USE	36
3.6	TECHNICAL DATA AND NOISE.....	37
3.7	WORK AND CONTROL STATIONS.....	38
4	TRANSPORT-HANDLING-STORAGE	40
4.1	PACKING AND UNPACKING.....	40
4.2	TRANSPORTING AND HANDLING THE PACKED MACHINE	41
4.3	TRANSPORTING AND HANDLING THE UNPACKED MACHINE	42
4.4	STORAGE OF PACKED AND UNPACKED MACHINE.....	43
5	INSTALLATION	44
5.1	PERMITTED AMBIENT CONDITIONS	44
5.2	FITTING THE UNITS.....	45
6	STARTING UP THE MACHINE	48
6.1	ELECTRICAL PANEL	48
6.2	INSTRUCTIONS FOR USE	49
6.2.1	LOADING A ROLL OF FILM.....	49
6.2.2	STARTING THE MACHINE.....	50
6.2.3	MANUAL MACHINE MOVEMENT	51
6.2.4	CYCLE STOP	51
6.2.5	STOPPING THE MACHINE AFTER USE	52
6.2.6	EMERGENCY STOP	52
6.3	ADJUSTMENTS.....	53
6.3.1	PRODUCT READING ARM ADJUSTMENT	53
6.3.2	SAFETY SYSTEMS EFFICIENCY CHECK.....	54
6.3.3	EMERGENCY BUTTONS OPERATIONAL CHECK.....	55
7	MAINTENANCE	56
7.1	GENERAL PRECAUTIONS	56
7.1.1	MACHINE DISCONNECTION	57

7.1.2	SPECIAL PRECAUTIONS.....	57
7.1.3	CLEANING.....	57
7.2	SCHEDULED MAINTENANCE	58
7.2.1	ACTIVE SAFETY DEVICES MAINTENANCE	59
7.2.2	WEEKLY MAINTENANCE.....	60
7.2.3	HALF-YEARLY MAINTENANCE.....	61
7.2.4	CHARGING THE BATTERY.....	61
8	OUT OF SERVICE	64
8.1	DISMANTLING, SCRAPPING AND DISPOSAL.....	64
8.2	DISMANTLING ELECTRONIC PARTS (WEEE DIRECTIVE).....	65

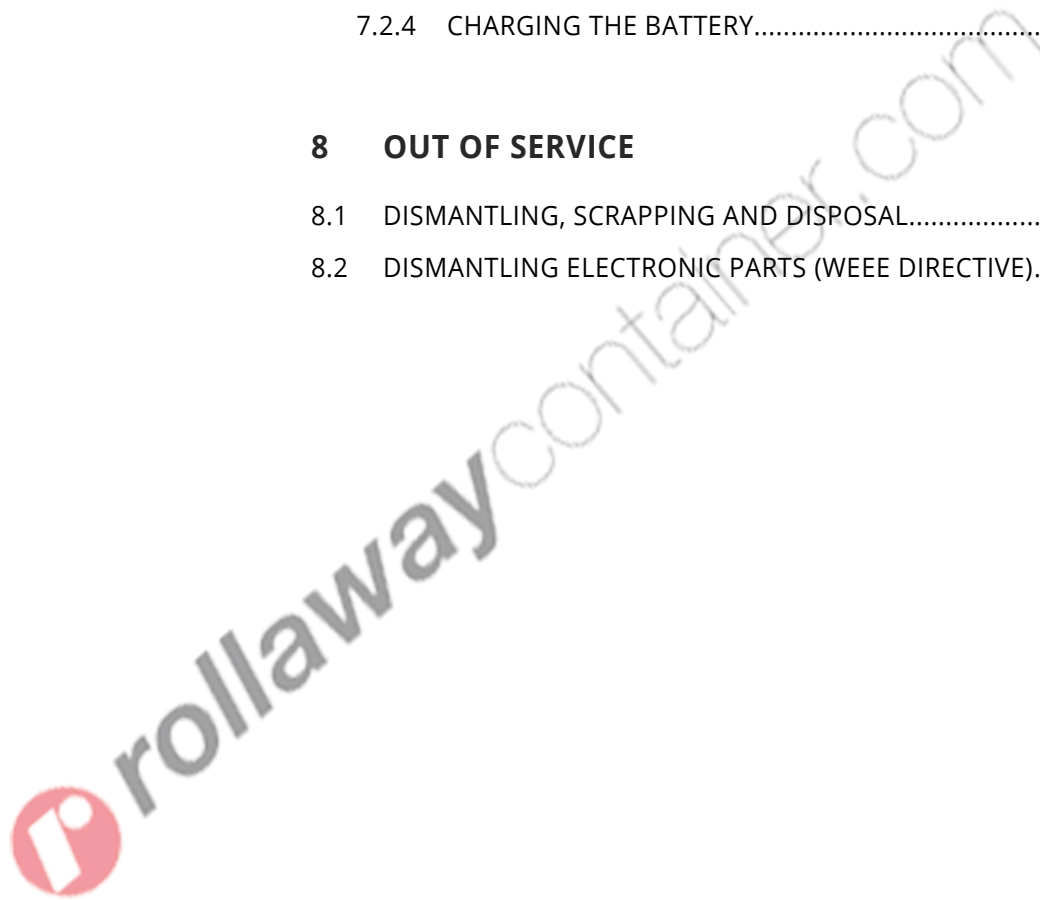

 rollawaycontainer.com

IT DICHIARAZIONE CE DI CONFORMITA'	RU CE ДЕКЛАРАЦИЯ О СООТВЕТСТВИИ	SE EG-FÖRSÄKRAN OM ÖVERENSSTÄMMELSE
EN EC DECLARATION OF CONFORMITY	HU EK MEGFELELÉSI NYILATKOZAT	NL EG-VERKLARING VAN OVEREENSTEMMING
DE EG-KONFORMITÄTSEKTLÄRUNG	PL DEKLARACJA ZGODNOŚCI WE	CZ ES PROHLÁŠENÍ O SHODĚ CONFORMIDADE
FR DECLARATION DE CONFORMITE CE	DA EF-ÖVERENSSTÄMMELSESERKLÄRING	FI EY-VAATIMUSTENMUKAISUUSVAKUUTUS
ES DECLARACIÓN DE CONFORMIDAD CE		PT DECLARAÇÃO CE DE CONFORMIDADE

IT IL FABBRICANTE E PERSONA AUTORIZZATA A COSTITUIRE IL FASCICOLO TECNICO:	RU ИЗГОТОВИТЕЛЬ И ЛИЦО, УПОЛНОМОЧЕННОЕ СОСТАВИТЬ ТЕХНИЧЕСКУЮ ДОКУМЕНТАЦИЮ:	SE TILLVERKAREN OCH PERSON SOM ÄR BEHÖRIG ATT SAMMANSTÄLLA DEN TEKNISKA DOKUMENTATIONEN:
EN THE MANUFACTURER AND AUTHORISED PERSON TO COMPILE THE TECHNICAL FILE:	HU A MŰSZAKI DOKUMENTÁCIÓ ÖSSZEÁLLÍTÁSÁVAL MEGBIZOTT SZEMÉLY:	NL DE FABRIKANT EN PERSOON DIE GEAUTORISEERD IS OM HET TECHNISCH DOSSIER OP TE STELLEN:
DE DER HERSTELLER IST DIE ZUR ERSTELLUNG DER TECHNISCHEN UNTERLAGEN BEFUGTE PERSON:	PL PRZYGOTOWANIA DOKUMENTACJI TECHNICZNEJ:	CZ VÝROBCE A OSOBA OPRAVNĚNÁ K SESTAVENÍ TECHNICKÉHO SOUBORU:
FR LE FABRICANT ET LA PERSONNE AUTORISÉE À CONSTITUER LE DOSSIER TECHNIQUE:	DK PRODUCENTEN ER AUTORISERET TIL AT UDFØRE DEN TEKNISKE DOKUMENTATION:	FI VALMISTAJA JA TEKNISEN TIEDOTTEEN LAADINTAAN VALTUUTETTU HENKILÖ:
ES EL FABRICANTE Y LA PERSONA AUTORIZADA PARA ELABORAR EL INFORME TÉCNICO:		PT O FABRICANTE E PESSOA AUTORIZADA A CONSTITUIR FASCÍCULO TÉCNICO:

ATLANTA STRETCH Spa, via Torrianese, 58 - 47824 POGGIO TORRIANA (RN) - ITALY

IT DICHIARA SOTTO LA PROPRIA RESPONSABILITÀ CHE LA MACCHINA IDENTIFICATA	RU ЗАВЯЛЯЕТ ЧТО ОБМОТЧИК СООТВЕТСТВУЕТ ТРЕБОВАНИЯМ	SE FÖRSÄKRAR HÄRMED ATT MASKINEN MED FÖLJANDE EGENSKAPER
EN DECLARES ON HIS OWN RESPONSIBILITY THAT THE MACHINE IDENTIFIED AS FOLLOW	HU SAJÁT FELELŐSÉGÉRE KIJELENTI, HOGY AZ ALÁBBIAK SZERINT ÁZONOSÍTOTT	NL VERKLAART VOOR EIGEN VERANTWOORDELIJKHEID, DAT DE GEÏDENTIFICEERDE MACHINE
DE ERKLÄRT UNTER EIGENER VERANTWORTUNG DASS DIE IDENTIFIZIERTE MASCHINE	PL OŚWIADCZA NA WŁASNĄ ODPOWIEDZIALNOŚĆ IŻ OZNACZONA MASZYNA GEP	CZ PROHLÁŠUJI NA SVOU ZODPOVĚDNOST ŽE STROJ S NÁSLEDUJÍCÍM OZNAČENÍM
FR DECLARE SOUS SA RESPONSABILITE QUE LA MACHINE IDENTIFIEE	DK ERKLÆRER PÅ EGET ANSVAR, AT MASKINEN IDENTIFICERET SOM	FI VAKUUTETA O MALLA VASTUULLAAN, ETTÄ ILMOITETTU LAITE
ES DECLARA BAJO SU RESPONSABILIDAD QUE LA MÁQUINA IDENTIFICADA		PT DECLARA SOB SUA PRÓPRIA RESPONSABILIDADE QUE A MÁQUINA IDENTIFICADA

IT TIPO: AVVOLGITORE	RU ТИП: ОБМОТЧИК	SE TYP: STRÄCKFILMSMASKIN
EN TYPE: WRAPPING MACHINE	HU TÍPUS: TEKERCELŐ	NL TYPE: BANDEROLEUSE
DE TYP: WICKELMASCHINE	PL TYP: OWIJARKA	CZ TYP: BALÍČÍ STROJ
FR TYPE: BANDEROLEUSE	DK TYPE: VIKLEMASKINE	FI TYYPPI: LAVAKÄÄRINTÄLAITE
ES TIPO: ENFARDADORA		PT TYPE: ENVOLVEDOR

IT MODELLO	RU МОДЕЛЬ	SE MODELL
EN MODEL	HU MODEL	NL MODEL
DE MODELL	PL MODEL	CZ MODEL
FR MODÈLE	DK MODEL	FI MALLI
ES MODELO		PT MODELO

IT MATRICOLA	RU СЕРИЙНЫЙ НОМЕР	SE SERIENUMMER
EN SERIAL NUMBER	HU SOROZATSZÁMA	NL SERIENUMMER
DE SERIENUMMER	PL NUMER FABRYCZNY	CZ SÉRIOVÉ ČÍSLO
FR NUMÉRO DE SÉRIE	DK SERIENUMMER	FI SARJANUMERO
ES N° SERIE		PT N° DE SÉRIE

IT E' CONFORME ALLE DIRETTIVE COMUNITARIE	RU СООТВЕТСТВУЕТ ДИРЕКТИВАМ ЕВРОПЕЙСКОГО СООБЩЕСТВА	SE ÄR TILLVERKAD I ÖVERENSSTÄMMEISE MED GÄLLANDE EU-DIREKTIV
EN IN CONFORMITY WITH THE FOLLOWING DIRECTIVES	HU MEGFELEL A VONATKOZÓ EURÓPAI IRÁNYELVEKNEK	NL CONFORM IS MET COMMUNAUTAIRE RICHTLIJNEN INZAKE
DE ES DEN FOLGENDEN EU-RICHTLINIEN ENTSPRICHT	PL JEST ZGODNA Z ODPOWIEDNIMI DYREKTYWAMI WSPÓLNOTOWYMI	CZ JE V SOULADU S NÁSLEDUJÍCÍ SMĚRNICÍ
FR EST CONFORME AUX DIRECTIVES COMMUNAUTAIRES RELATIVES AUX/A	DK ER UDARBEJDET I ÖVERENSSTÄMMELSE MED DE GÄLDENDE EU-DIREKTIVER	FI ON SEURAAVIEN YHTEISÖN DIREKTIVIEN MUKAINEN
ES ES CONFORME A LAS DIRECTIVAS COMUNITARIAS SOBRE		PT ESTÁ EM CONFORMIDADE COM AS DIRETIVASOMUNITARIAS

2006/42/CE & 2014/30/UE

IT E NORME	RU И НОРМЫ	SE OCH STANDARDER
EN AND STANDARDS	HU ÉS NORMÁK	NL EN NORMEN
DE UND NORMEN	PL I NORMY	CZ A NORMY
FR ET NORMES	DK OG STANDARDER	FI JA MÄÄRÄYKSET
ES Y NORMAS		PT E NORMAS

EN ISO 12100:2010 & EN 60204-1:2006

IT DICHIARAZIONE ORIGINALE IN LINGUA ITALIANA.	RU ПЕРЕВОД ОРИГИНАЛА ДЕКЛАРАЦИИ НА ИТАЛЬЯНСКОМ ЯЗЫКЕ.	SE ÖVERSÄTTNING ORIGINALDEKLARATION PÅ ITALIENSKA.
EN TRANSLATION OF ORIGINAL DECLARATION IN ITALIAN.	HU FORDÍTÁS AZ EREDETI NYILATKOZAT OLASZ NYELVŰ.	NL VERTALING VAN DE ORIGINELE VERKLARING IN HET ITALIAANS.
DE ÜBERSETZUNG DER ORIGINALERKLÄRUNG AUF ITALIENISCH.	PL TRANSLACJA ORYGINALNE OŚWIADCZENIE W JEZYKU WŁOSKIM.	CZ PŘEKLAD ORIGINÁLNÍ PROHLÁŠENÍ V ITALSKÉM JAZYKU.
FR TRADUCTION DES DÉCLARATION ORIGINALE EN LANGUE ITALIENNE.	DK ÖVERSÄTTELSE ORIGINAL ERKLÆRING PÅ ITALIENSK.	FI KÄÄNNÖS ALKUPERÄINEN ILMOITUS.
ES TRADUCCIÓN DE DECLARACIÓN ORIGINAL ENALIANO.		PT TRADUÇÃO DECLARAÇÃO ORIGINAL EM ITALIANO.

IT LUOGO E DATA:	RU МЕСТО И ДАТА:	SE ORT OCH DATUM:
EN PLACE AND DATE:	HU KELLT:	NL PLAATS EN DATUM:
DE ORT UND DATUM:	PL MIEJSCE I DATA:	CZ MÍSTO A DATUM:
FR LIEU ET DATE :	DK DATO OG STED:	FI PAIKKA JA PÄIVÄYS:
ES LUGAR Y FECHA:		PT LOCAL E DATA:

Poggio Torriana

IT IL LEGALE RAPPRESENTANTE (ANGELO FORNI)	RU ЮРИДИЧЕСКИЙ ПРЕДСТАВИТЕЛЬ (ANGELO FORNI)	SE JURIDISKT OMBUD (ANGELO FORNI)
EN LEGAL REPRESENTATIVE (ANGELO FORNI)	HU A TÖRVÉNYES KÉPVISELŐ (ANGELO FORNI)	NL DE WETTTELJKE VERTEGENWOORDIGER(ANGELO FORNI)
DE GESETZLICHER VERTRETER (ANGELO FORNI)	PL PRZEDSTAWICIEL USTAWOWY (ANGELO FORNI)	CZ PŘÁVNÍ ZÁSTUPCE (ANGELO FORNI)
FR LE REPRÉSENTANT LÉGAL (ANGELO FORNI)	DK DEN ADMINISTRERENDE DIREKTØR (ANGELO FORNI)	FI LÄÄLLINEN EDUSTAJA (ANGELO FORNI)
ES EL REPRESENTANTE LEGAL (ANGELO FORNI)		PT O REPRESENTANTE LEGAL (ANGELO FORNI)

ATLANTA STRETCH S.p.a.

 rollawaycontainer.com

1 FOREWORD

1.1 HOW TO READ AND USE THE INSTRUCTIONS MANUAL

1.1.1 THE IMPORTANCE OF THE MANUAL

The instruction manual is to be considered as an integral part of the product; keep it and look after it throughout the lifetime of the machine and hand it on to any other users or subsequent owners.

All the instructions contained in the manual must be followed by both operators and qualified staff in order to correctly and safely install, start, use and service the machine.

In the event of doubts or problems, contact the technical service centres.

1.1.2 SAFE KEEPING THE MANUAL

Use the manual in such a way as not to damage all or part of the contents.

On no account should any parts of this manual be removed, torn out or rewritten.

Keep the manual in places protected from humidity and heat.

Keep this manual and all the related publications in an accessible place known to all the operators.

All use and maintenance operations concerning commercial machine components that are not indicated in this manual are contained in the relative publications attached to it.

1.1.3 CONSULTING THE MANUAL

This instruction manual is made up of:

- COVER WITH MACHINE IDENTIFICATION
- INSTALLATION AND ASSEMBLAGE
- INSTRUCTIONS AND/OR NOTES ON SAFETY USE OF THE PRODUCT
- ATTACHMENTS

1.1.4 COPYRIGHT

This manual contains confidential industrial information belonging to MANUFACTURER.

All rights are reserved and may be protected by copyright or other ownership laws and treaties.

No part of this manual may be reproduced in any form or by any means without explicit permission from MANUFACTURER.

1.1.5 INFORMATION ON THE IMAGES AND CONTENTS

The illustrations in this manual have been included solely by way of example for better understanding of what is described.

This document may be subject to change by Manufacturer without prior notice, but the information on safe use is still guaranteed.

1.1.6 UPDATE OF THE INSTRUCTION MANUAL

The essential features of the type of machine described being understood, Manufacturer reserves the right to make any modifications to the devices, details and accessories as it sees fit for product improvement or for construction or commercial requirements.

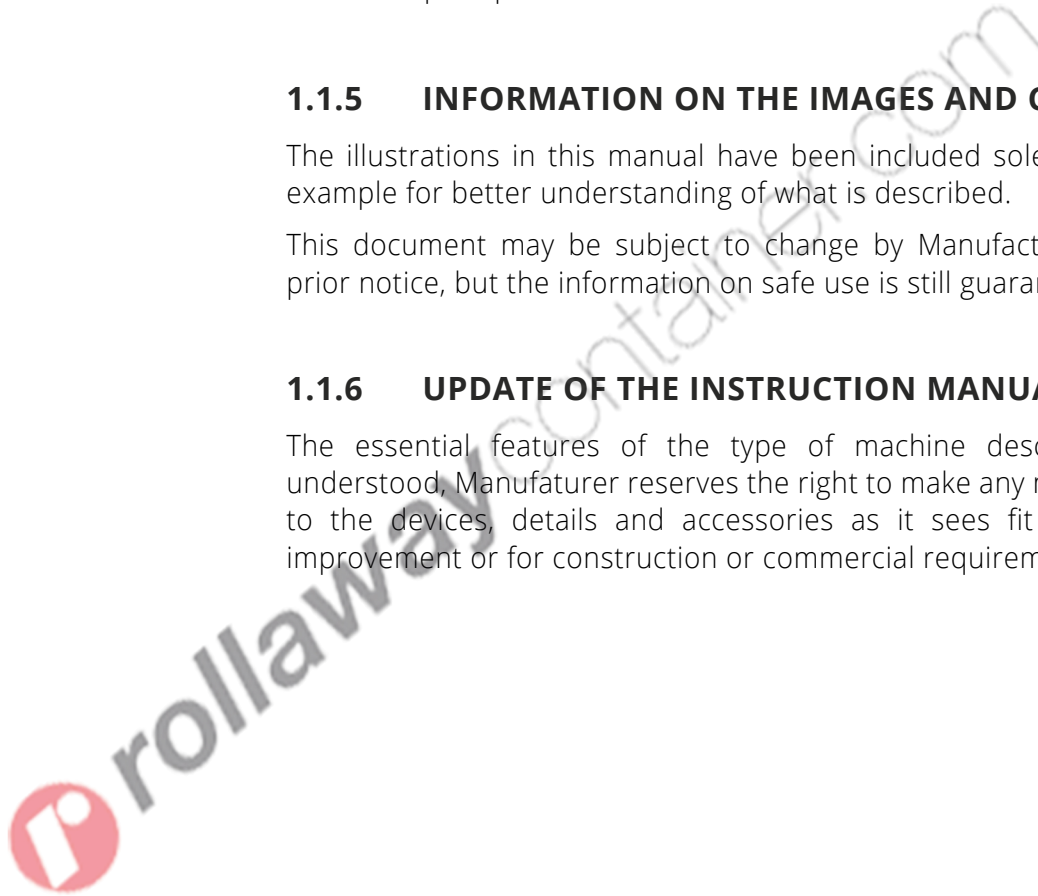

1.1.7 SYMBOLS – MEANING AND USE

Typographic messages and symbols are used in this manual to refer to particular procedures which, if not observed, could cause damage to people, animals, things and the environment.

DANGER



*Indicates a hazard with the risk of mortal injury.
Failure to observe warnings marked by this symbol can lead to a situation of serious risk to the safety of the operator and/or exposed persons.*

WARNING



*Indicates a hazard with the risk of danger to the machine or the product being processed.
Failure to observe warnings marked by this symbol can lead to malfunction or damage to the machine.*

INFORMATION



Indicates notes and advice for practical machine use in the different operating modes.

1.2 WHO THE MANUAL IS FOR



MACHINE OPERATOR:

Operator who, after an appropriate training course in the use of the machine, is able to make the simplest adjustments.



MECHANICAL MAINTENANCE TECHNICIAN:

Qualified technician able to operate the machine like the machine operator and work on the mechanical devices for adjustment, maintenance and repair. The mechanical maintenance technician is not qualified to perform operations on live electrical systems.



MAINTENANCE ELECTRICIAN:

Qualified technician able to operate the machine like the machine operator, make adjustments and work on electrical systems for maintenance and repair.



SPECIALISED TECHNICIAN OF THE MANUFACTURER:

Qualified technician of the manufacturer or his distributor able to operate the machine like the machine operator, work on the mechanical devices and on the electrical system for adjustments, maintenance, repairs and complex operations when agreed with the user.



EXPOSED PERSON:

Any person partially or fully in a hazardous zone.

2 SAFETY

2.1 GENERAL SAFETY INSTRUCTIONS

Before starting work, the operator must be perfectly familiar with the position and functioning of all the controls and machine features. Daily check all the safety devices on the machine.

- Before starting the working cycle, the operator must ensure that there are no EXPOSED PERSONS in the HAZARDOUS ZONES.
- The employer must provide and instigate the use of personal protective equipment conforming to the prescriptions of Directive 89/391/EEC (and subsequent revisions). While using and carrying out maintenance on the machine the use of personal protective equipment (PPE) such as safety footwear and overalls, approved for accident prevention, is obligatory.
- The areas where the operator stands must always be kept clear and free of oily residues.
- It is forbidden to approach the moving parts of the machine, such as the carriage and rotating parts, when the machine is in operation.
- It is strictly prohibited to operate the machine in automatic mode with the fixed and/or mobile safety guards removed.
- It is strictly prohibited to disable the safety devices installed on the machine.
- Any adjustment operations that need to be carried out with some of the safety devices disabled must be performed by one person only, and unauthorised persons may not access the machine during this time.
- The room in which the machine is housed must not have any shadow areas, annoying bright lights or hazardous stroboscopic effects caused by the lighting supplied.
- The machine can operate in clear air conditions at ambient temperatures of +5°C to +40°C.
- The machine must be used exclusively by qualified personnel.

DANGER



THE MACHINE MUST ONLY BE USED BY ONE OPERATOR AT A TIME, USE OF THE MACHINE BY 2 OR MORE OPERATORS AT THE SAME TIME IS FORBIDDEN.

DANGER



During all maintenance, repair or adjustment operations, IT IS OBLIGATORY TO TURN THE MAIN SWITCH TO (0-OFF).

If you need to conduct work inside the electrical panel, always turn off the voltage upstream the machine using the mains switch, as the terminal board is powered on even though the panel is open and the machine switch is set to "OFF".

It is advisable to post a warning sign on the control panel onboard the machine or on the main power switch (whatever applicable); this sign should read as follows:

WARNING! DO NOT TOUCH - MAINTENANCE STAFF AT WORK.

DANGER



DO NOT REMOVE THE FIXED GUARDS WHEN THE MACHINE IS RUNNING. ALWAYS REFIT THE FIXED GUARDS AFTER ANY MAINTENANCE OPERATION.

DANGER



IT IS PROHIBITED TO ATTEMPT TO COUNTERACT, SLOW DOWN OR STOP THE MACHINE DURING THE AUTOMATIC WRAPPING CYCLE. USE ONLY THE STOP BUTTON OR THE EMERGENCY BUTTON TO BRING IT TO A HALT.

As soon as possible after an operation that required disabling of some safety devices, the machine must be restored to a safe state by re-enabling all the safety devices.

Do not for any reason modify parts of the machine (e.g. attachments, holes, finishes, etc.) in order to adapt it to other devices. We therefore advise you to request any modifications directly from the Manufacturer.

2.2 SAFETY SIGNS

» See Picture 1 - pag. 9

The safety signs described in this manual, are located on the machine structure at suitable points and warn of the likelihood of danger due to residual risks.

The adhesive stickers, distinguished by yellow and black bands, warn of areas of risk for operators and so maximum care must be taken where these signs are located.

The adhesive stickers applied to the machine must always be kept clean and legible.



- High voltage hazard, electrical plug for battery charging cable.



- Risk of collision or being crushed



- it is forbidden to remove fixed safety guards.



- it is forbidden to transit or remain in areas with moving parts.



- it is obligatory to read the instruction manual carefully before operating the machine.



- Pick-up point for lifting and handling with a fork lift truck.



- Finger crushing hazard due to moving parts.



- Safety plate on the battery. The symbols draw attention to the obligations and prohibited actions relating to the use of lead batteries.

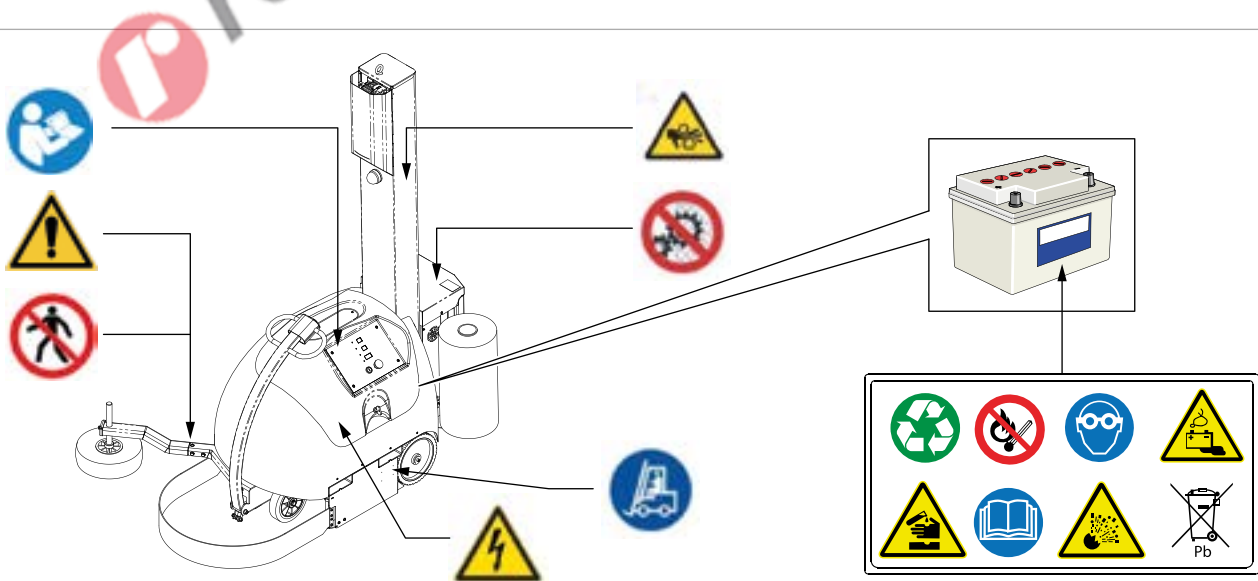

Picture 1

2.3 WARNINGS OF RESIDUAL RISKS

» See Picture 2 - pag. 10

The machine has been designed and constructed in such a way as to allow the operator to use it safely, eliminating or cutting down to the minimum the possible residual risks by the adoption of safety devices. It has not been possible however to eliminate some risks, listed below, because these are inherent in the way the machine works.

DANGER



RISK OF FALLING AND BECOMING TRAPPED

Never climb onto the machine (1) as there is the risk of falling and/or becoming trapped in moving parts.

DANGER



RISK OF COLLISION OR BEING CRUSHED

Do not approach the machine working area during the work cycle as there is the risk of colliding with it (2).

While operating the machine in manual mode, risk of being crushed between the machine and a fixed obstacle along the path.

DANGER



RISK OF ELECTROSTATIC SHOCK

The film (3) used for wrapping, can become charged with static electricity during the work cycle, depending on the air humidity, the type of material being wrapped and the type of flooring on which you are working. To prevent dangerous shocks when touching the film, the operator should wear dielectric footwear or use antistatic film. The machine is not suitable for working in explosive atmospheres.

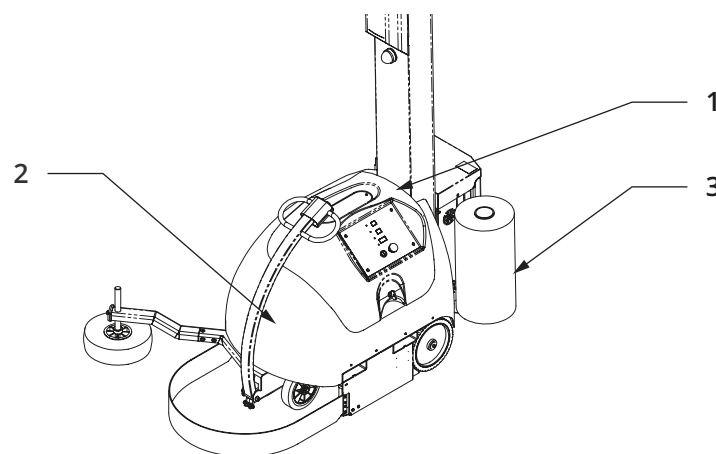

Picture 2

2.4 SAFETY DEVICES

DANGER



The machine has been designed and constructed to allow safe use in all the conditions intended by the manufacturer, isolating the moving parts and live components by the use of SAFETY GUARDS and SAFETY devices to stop the machine.

The manufacturer declines all responsibility for damage or injury to persons, animals or objects caused by tampering with the safety devices.

» See Picture 3 - pag. 11

- Emergency button **(A)** on the electrical panel.
- The top area of the carriage, where the drive transmission gears are, is protected by a fixed guard **(B)**.
- The safety bumper **(C)** is a flexible belt interlocked by a microswitch which stops the machine immediately in the event of impact with objects on the ground.

N.B: If the machine stops because the safety bumper **(C)** has been triggered, before restarting the work cycle remove the obstruction and then carry out the resetting procedure described in the start up paragraph.

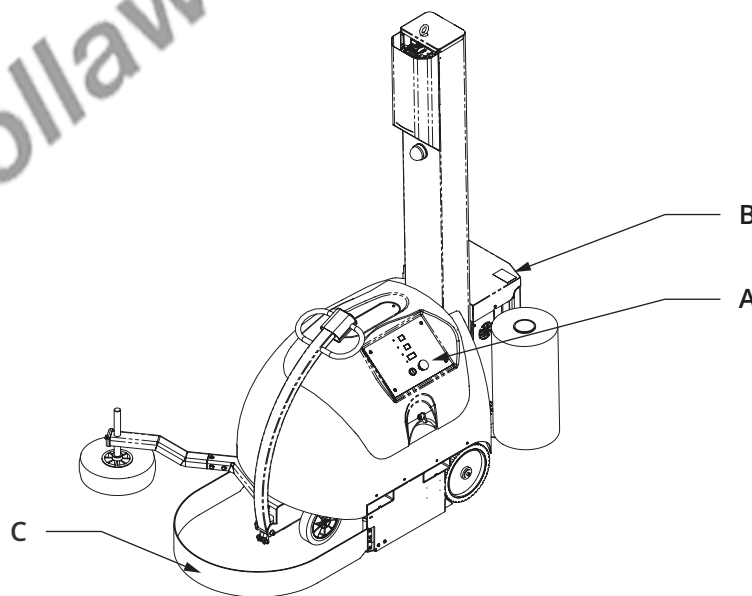

Picture 3

DANGER



Smooth or slippery floor surfaces may increase the time it takes to stop the machine under emergency stop situations.

DANGER



Do not remove the safety bumper, always refit the safety bumper after any maintenance operations.

DANGER



Do not remove the fixed guards with the machine running, always refit the fixed guards after any maintenance operations.

2.5 PERSONAL PROTECTIVE EQUIPMENT (PPE)

The following personal protective devices are necessary for handling, installation, use, maintenance, and dismantling.



- Compulsory use of gloves.



- Safety shoes required.



- Protective clothing required.



- Compulsory use of helmet.

2.6 TECHNICAL ASSISTANCE

For any orders, assistance or information, the user should contact the Manufacturer quoting the following details:

- Machine model
- Serial number
- Year of manufacture
- Purchase date
- Approximate number of service hours
- Detailed indications regarding a specific operation to be carried out or the fault found.

TECHNICAL ASSISTANCE

see COVER WITH MACHINE IDENTIFICATION

Best performance of our machines can only be maintained and guaranteed if original spare parts are used.

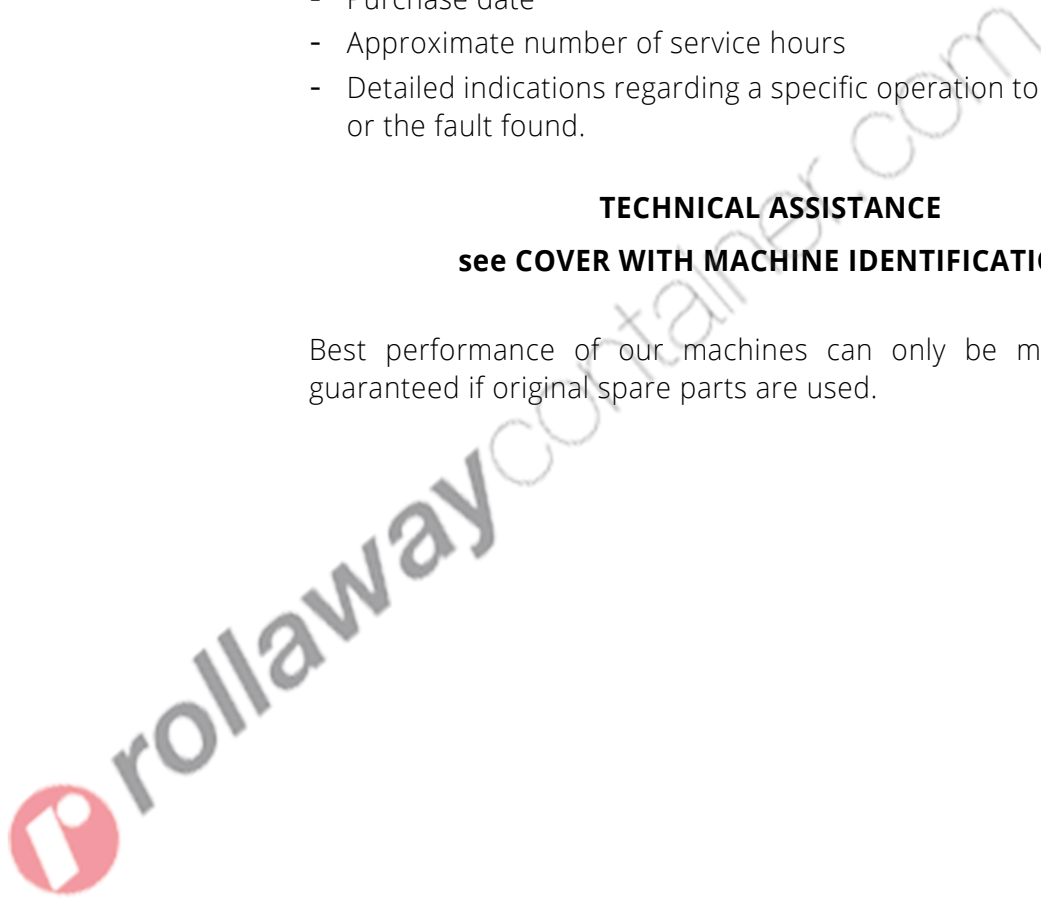

3 MACHINE DESCRIPTION

3.1 MANUFACTURER AND MACHINE IDENTIFICATION DATA

see **COVER WITH MACHINE IDENTIFICATION**

The Identification plate, fixed to the machine chassis, shows the following information:

- Manufacturer's name and address
- Machine type
- Machine model
- Serial number
- Year of manufacture
- Weight (kg)
- Nominal voltage (Un)
- Operating frequency (Hz)
- No. of phases
- Nominal current (In)
- Short circuit current (Icc)
- Air pressure (bar)
- Air consumption (Nl/cycle).

» See Picture 4 - pag. 14

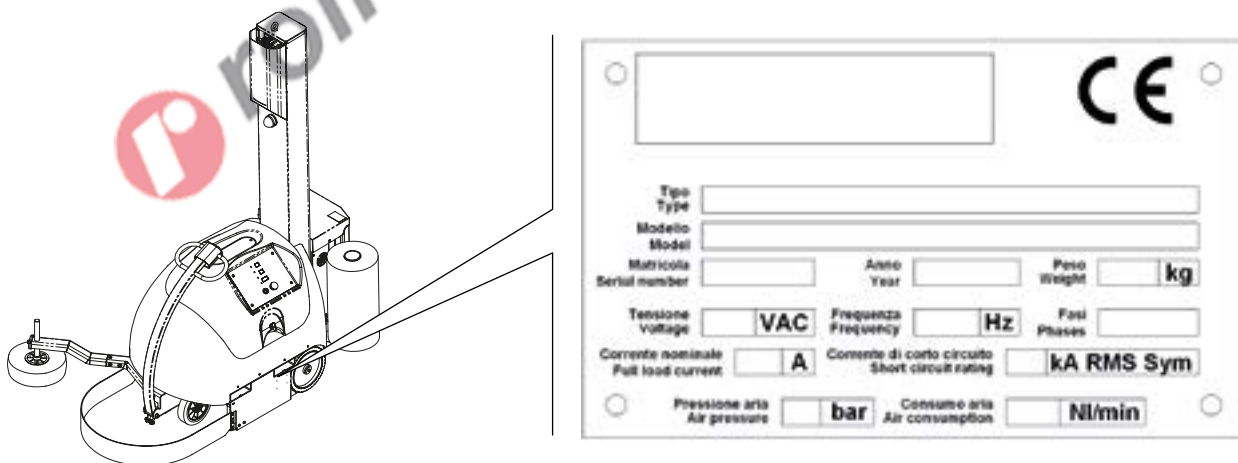

Picture 4

3.2 GENERAL DESCRIPTION

Self-propelled wrapping unit is a machine fitted with wheels and is designed to move independently around palletised products to wrap and stabilise them using stretch film. The machine is made up of the following main parts:

» See Picture 5 - pag. 15

- 1) **Self-propelled wrapping unit.** A semiautomatic machine used to wrap and stabilise product loads on pallets of any shape, using stretch film. The control panel is used to control the machine and to set the wrapping parameters. The Easy version allows simple adjustments while the Advanced version allows programs and wrapping methods to be used in a quick and versatile manner.
- 2) **Column** along which a wrapping tool (wrapping carriage) moves vertically up and down; the vertical movement of the wrapping carriage combined with rotation of the machine allows wrapping the product.
- 3) **Battery charger.** The built-in battery charger controls the recharging phases and gives an indication of the efficiency of the batteries (12) (see the technical manual supplied). When the battery charger is connected to the electrical power supply the machine cannot be started.

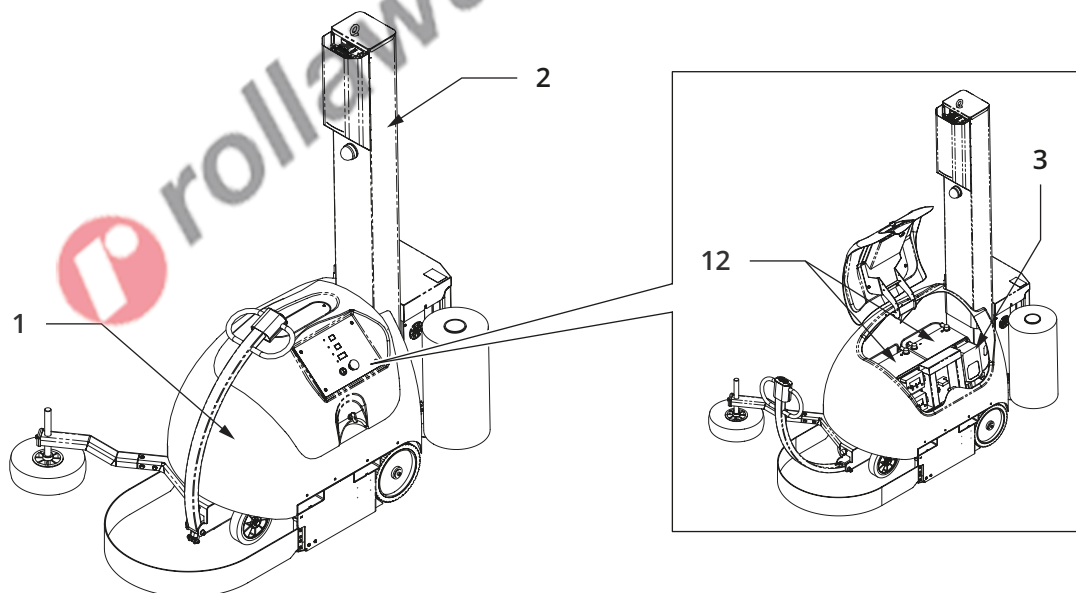

Picture 5

» See Picture 6 - pag. 16

- 4) **The Feeler wheel**, connected to the side arm (**11**), is placed up against the pallet on which the product to be wrapped stands and its purpose is to guarantee a more or less constant distance between the product and the machine.
- 5) **The Steering arm** works on the two front wheels (**9**) and is used by an operator to guide the machine in brief movements inside the workshop. For medium and long distance movement the machine must be moved using a fork lift truck. During the work cycle the steering arm is kept constantly turned by a spring, so that the machine turns around the product being wrapped.
- 6) **The control panel** allows programs to be used and wrapping parameters set in a simple and practical manner.
- 7) **The Drive wheel** at the back is activated by the DC motor (**8**) and allows the machine to move autonomously, signalled by the red flashing light (**10**).

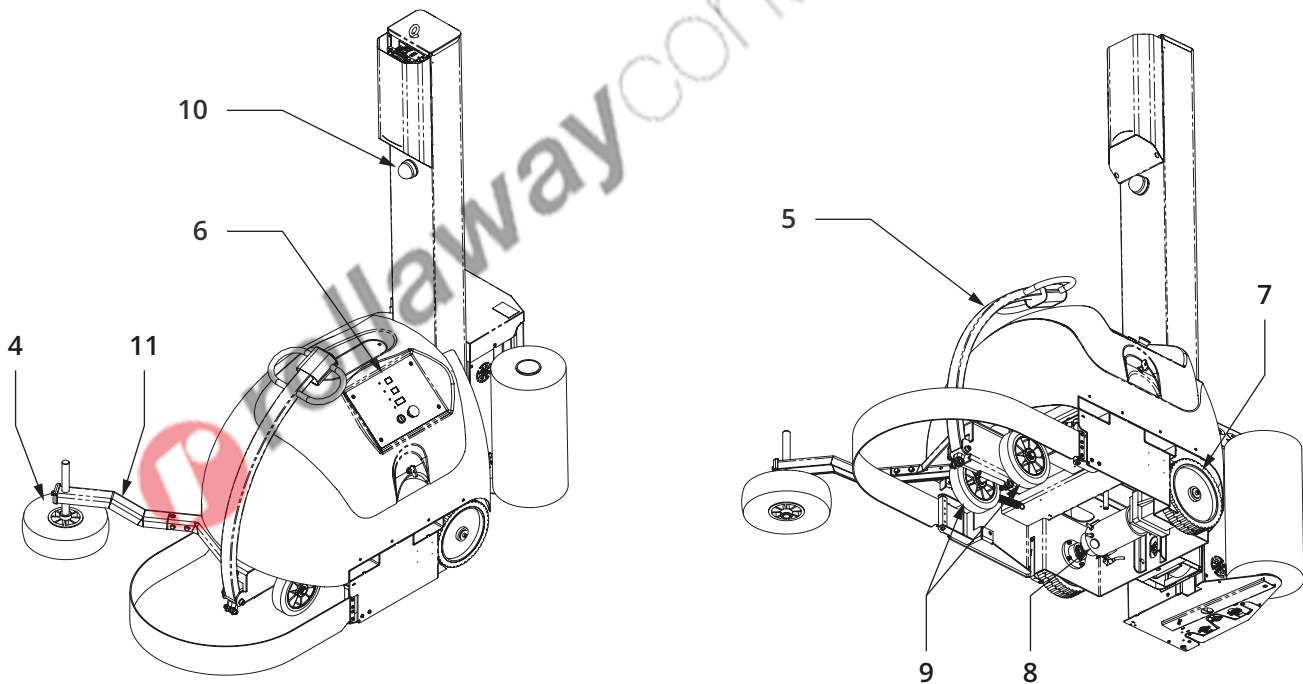

Picture 6

The machine can be fitted with one of the following four winding carriages: FM - FE - PRS and PS (MB-EB-EMPS/MPS-MPS2).

FM (MB) carriage: delivers film during winding and adjusts its application tension. Tension is governed by a roller fitted with a mechanical brake which can be manually adjusted with a knob located on the carriage.

FE (EB) carriage: delivers film during winding and adjusts its application tension. Tension is governed by a roller fitted with an electromagnetic brake which can be manually adjusted with a knob located on the carriage.

PRS / MPS carriage: delivers film during wrapping and adjusts its application tension to the load. The carriage can pre-stretch the film by means of a mechanical control generated by a pair of gears (fixed mechanical ratio). Application tension is controlled by a sensor which measures its value.

PS (MPS2) carriage: delivers film during winding and adjusts its application tension to the load. The carriage can pre-stretch the film at a variable ratio which is set from the operator's panel. Application tension is manually adjusted and controlled by a sensor which measures its value.

For specific information on the carriages, see par. "3.3 ROLL HOLDER CARRIAGES" pag. 20.

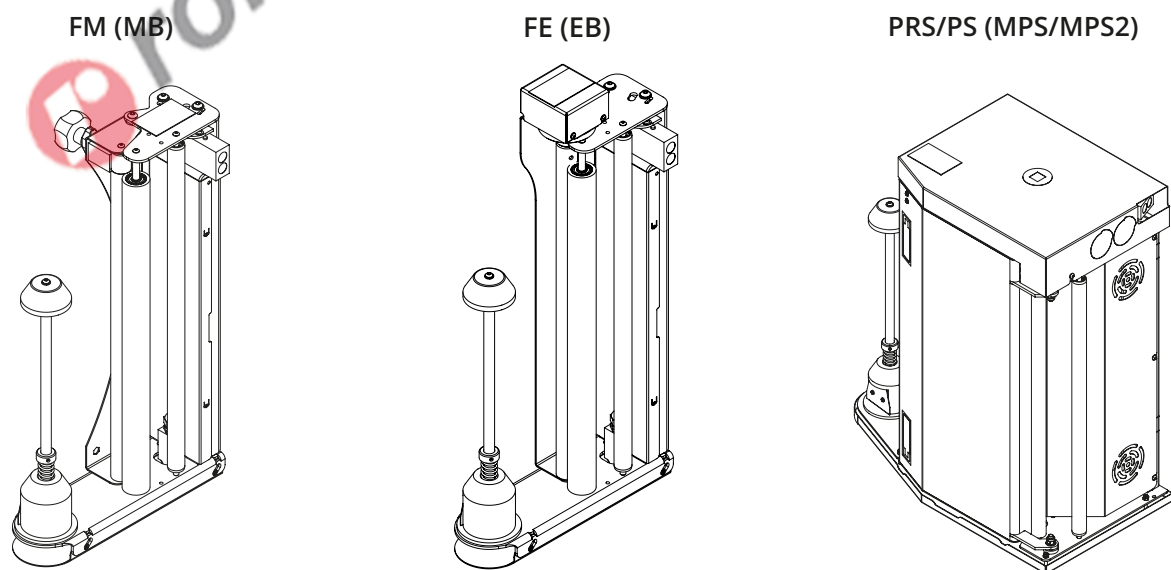

Picture 7 - Wrapping carriages available

Upon request, the machine can be supplied with the following optional devices that replace the standard components:

Battery

- Standard battery: a pair of 12 V batteries, about 100Ah, autonomy in average conditions: 150/180 winding cycles.
- Optional battery: one 24V battery, about 100Ah, autonomy in average conditions: 220/230 winding cycles.

Feeler Wheel

- 1) Standard feeler wheel: a Ø 300 wheel.

1

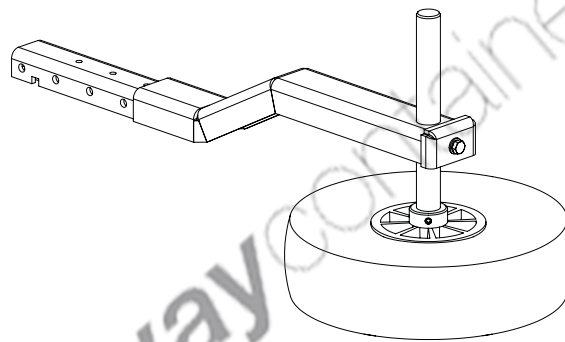

Picture 8

- 2) Wide feeler wheel: Ø 400/500/600 wheels for non-linear product profiles.

2

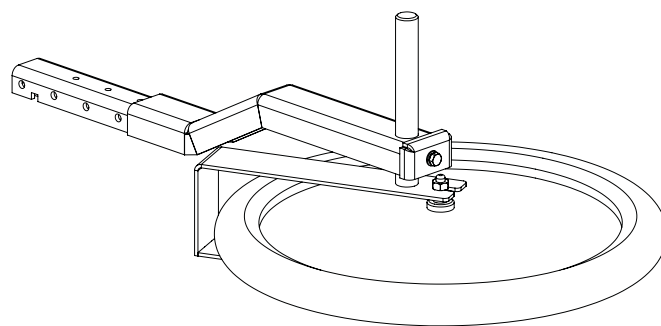

Picture 9

- 3) Double aligned feeler wheel: two Ø 300 wheels fitted on the same axis for product profiles at different heights.

3

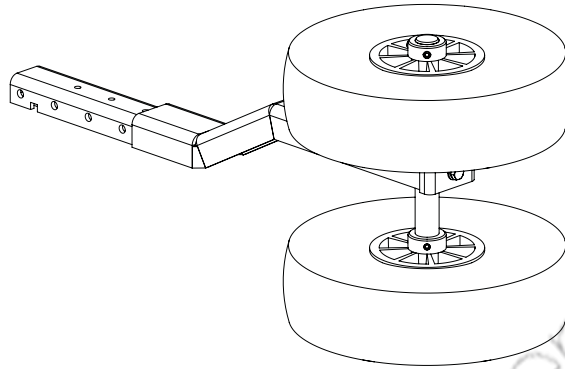

Picture 10

- 4) Double feeler wheel in line: two Ø 300 wheels fitted in line and tilting for product profiles with recesses.

4

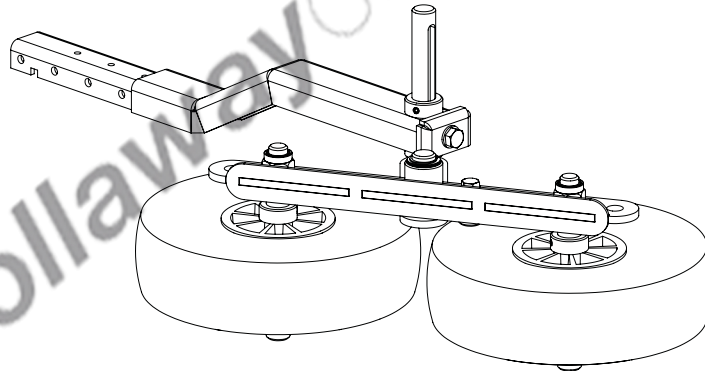

Picture 11

3.3 ROLL HOLDER CARRIAGES

FM / MB roll-holder carriage

» See Picture 12 - pag. 20

With this carriage version, the application tension of the film on the pallet can be adjusted.

The carriage **FM (MB)** is composed of a rubber-coated roller **(1)** and a roller **(2)** with mechanical brake.

The knob **(3)** is used to adjust the action of the brake and, consequently, the tension of the film.

Upon starting, the film must be loaded onto the carriage as follows.

- Put the carriage into the down position to make fitting the roll easier.
- Press the emergency button to stop the machine.
- Push the roll **(4)** onto the centre pin **(5)**.
- Insert the film between the rollers following the path indicated in figure **(A)**, the symbol with the triangles identifies the side of the film to which the bonding agent (if present) is applied.
- Diagram **(A)** is an adhesive sticker also affixed to the carriage.
- Tightening the knob **(3)** increases the tension of the film, loosening decreases it. Once the proper adjustment has been found, the position of the knob **(3)** is set by tightening the lock nut **(6)**.

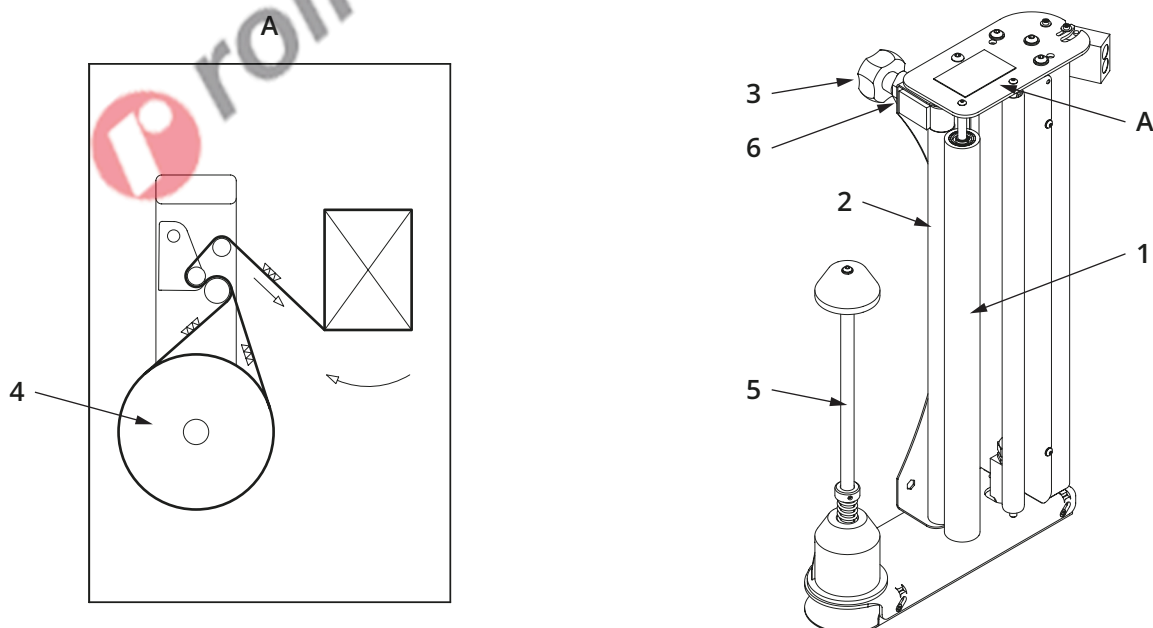

Picture 12

FE / EB roll-holder carriage

» See Picture 13 - pag. 21

With this carriage version, the application tension of the film on the pallet can be adjusted.

The **FE** carriage is made up of a rubber idle roller **(1)** and a roller **(2)** equipped with an electromagnetic brake.

Setting **F13-16 (F32)** functions in the control panel is used to adjust the action of the brake and, consequently, the tension of the film.

Upon starting, the film must be loaded onto the carriage:

- Put the carriage into the Down position to make fitting the roll easier.
- Press the emergency button to stop the machine.
- Push the roll **(4)** onto the centre pin **(5)**.
- Insert the film between the rollers following the path indicated in figure **(A)**, the symbol with the triangles identifies the side of the film to which the bonding agent (if present) is applied.
- Diagram **(A)** is also attached to the carriage.

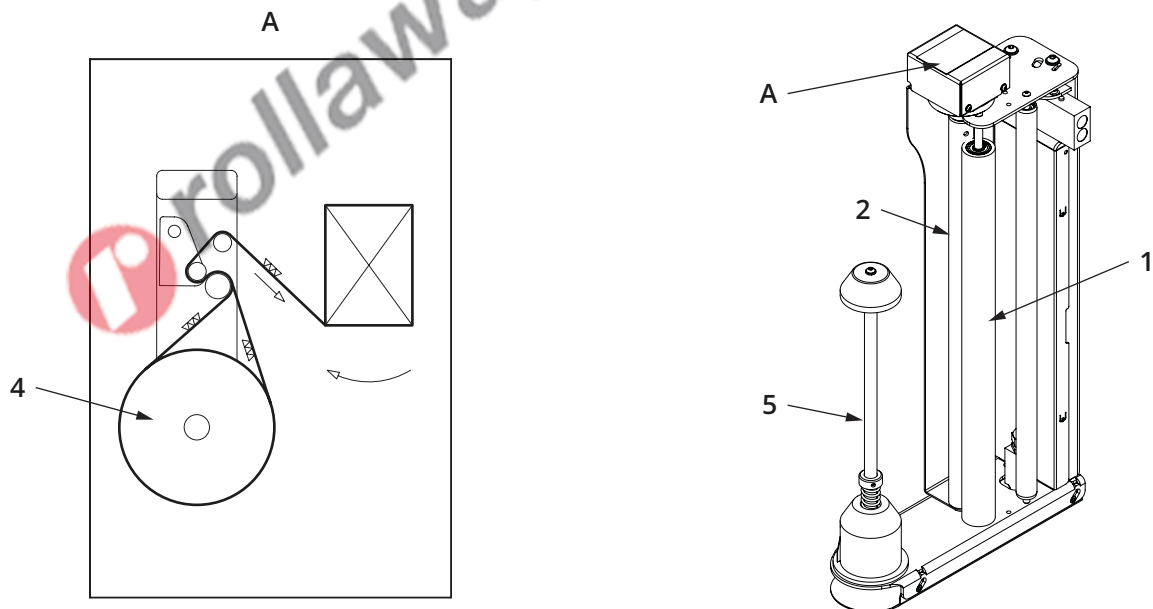

Picture 13

» See Picture 14 - pag. 23

PRS / MPS roll-holder carriage

With this carriage version, the application tension of the film on the pallet.

This carriage can pre-stretch the film according to fixed ratios determined by interchangeable gears.

The pre-stretch ratios are:

- **150%** (1 metre of film is pre-stretched to a length of 2.5 metres);
- **200%** (1 metre of film is pre-stretched to a length of 3.0 metres);
- **250%** (1 metre of film is pre-stretched to a length of 3.5 metres);
- **270%** (1 metre of film is pre-stretched to a length of 3.7 metres);
- **300%** (1 metre of film is pre-stretched to a length of 4.0 metres).

The carriage is fitted with a sensor **(4)**, connected to the outlet roller, which measures the tension of the film applied to the pallet.

A specific electronic card integrates the signal of the sensor **(4)** with the adjustment set with setting **F13-16 (F32)** functions in the control panel in order to dynamically control the speed of the pre-stretch roller drive motor and thus the film tension.

The carriage is fitted with a gearmotor which drives three rubber-surfaced rollers **(1)**, **(2)** and **(3)** by means of toothed gearing.

The different transmission ratios generate different speeds of the rollers **(1)**, **(2)** and **(3)** creating the pre-stretch action.

The carriage also features a set of 3 idle rollers which are used to increase the winding angle of the film on the rubber-coated rollers.

Upon starting, the film must be loaded onto the carriage.

- Put the carriage into the Down position to make fitting the roll easier.
- Press the emergency button to stop the machine.
- Push the roll **(7)** onto the centre pin **(8)**.
- Open the door and insert the film between the rollers following the path indicated in figure **(A)**, the symbol with the triangles identifies the side of the film to which the bonding agent (if present) is applied.
- Diagram **(A)** is also attached to the carriage.
- Close the door making sure it is correctly secured.

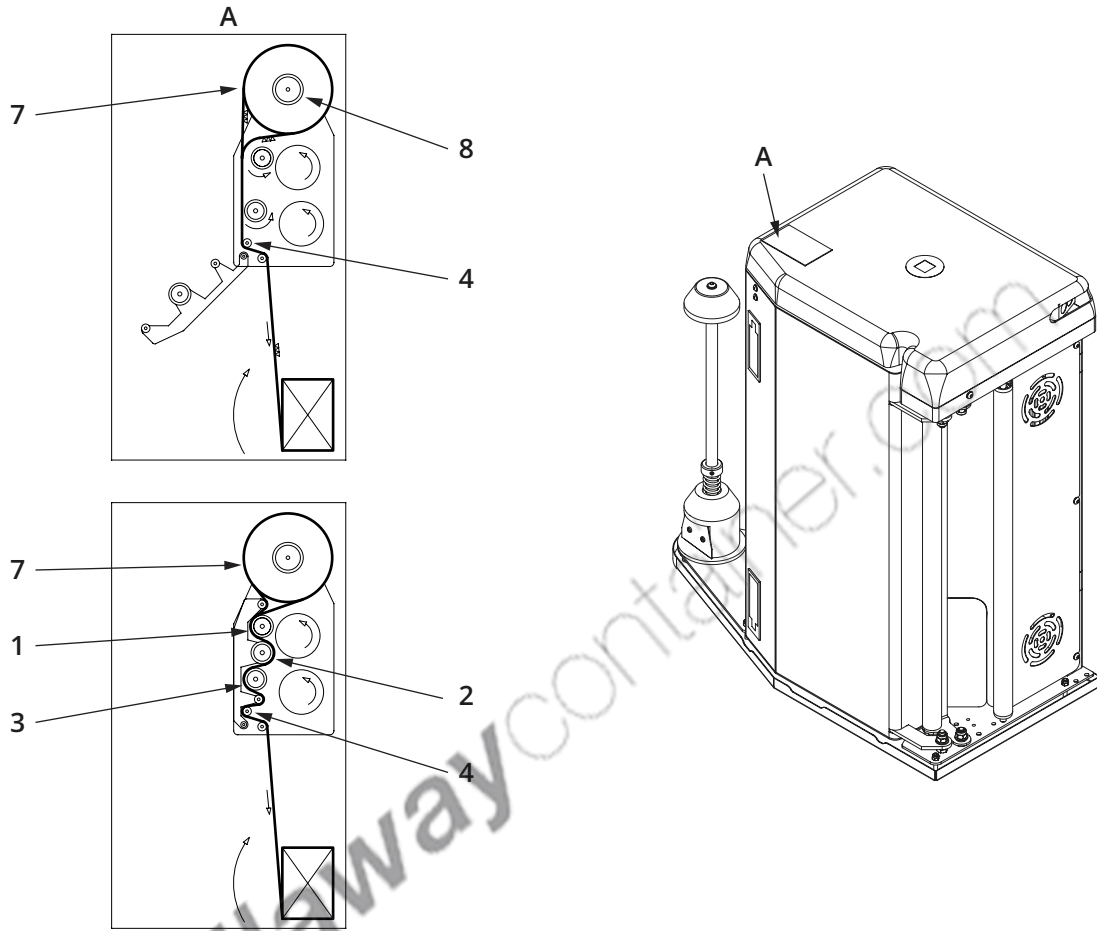

Picture 14

» See Picture 15 - pag. 25

PS / MPS2 roll-holder carriage

With this carriage version, the tension with which the film is applied to the pallet.

This carriage allows pre-stretching the film. Pre-stretch value can be set between **120%** and **400%**.

The carriage is fitted with:

- a sensor **(4)**, connected to the outfeeder to the pallet;
- two gearmotors which drive the rubber-coated roller **(1)**, **(2)** and **(3)** by means of toothed gearing;
- three idle rollers which are used to increase the winding angle of the film on the rubber-coated rollers.

A specific electronic card integrates the signal of the sensor **(4)** with the adjustment set with setting **F13-16 (F32-33)** functions in the control panel in order to dynamically control the speed of the pre-stretch roller drive motor and thus the film tension.

Can be adjusted using **F17-20** functions in the control panel controls the rotation of the roller **(1)** and **(2)**.

The speed difference generated between the rubber-coated rollers **(1),(2)** and **(3)** creates the pre-stretch action.

Upon starting, the film must be loaded onto the carriage.

- Put the carriage into the down position to make fitting the roll easier.
- Turn the main switch to the '**O**'-OFF position.
- Push the roll **(7)** onto the centre pin **(8)**.
- Open the door and insert the film between the rollers following the path indicated in figure **(A)**, the symbol with the triangles identifies the side of the film to which the bonding agent (if present) is applied.
- Diagram **(A)** is also attached to the carriage.
- Close the door making sure it is correctly secured.
- Turn the main switch to the '**I**' -ON position.

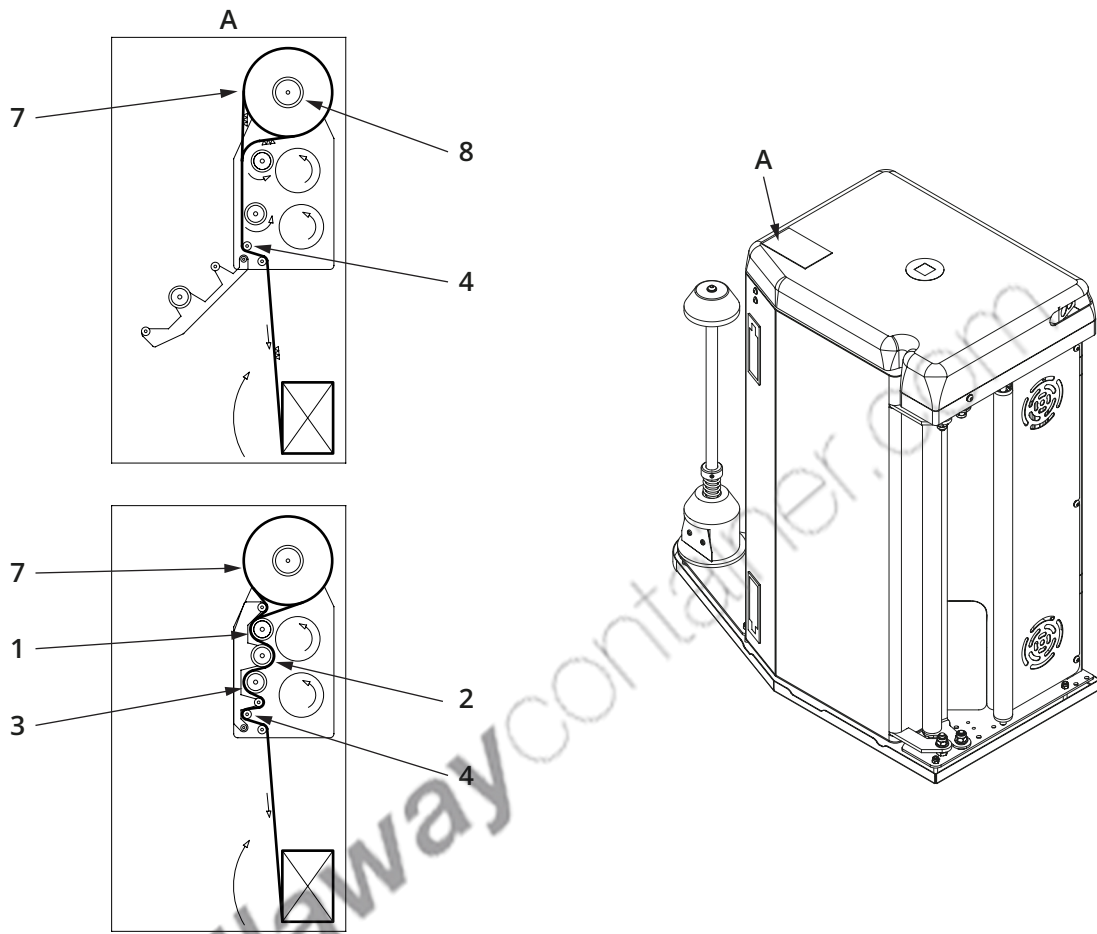

Picture 15

3.3.1 OPTIONAL EQUIPMENT

3.3.1.1 AUTOMATIC CUT

The automatic cycle can be used when the machine is equipped with the cutting unit, for cutting the film at the end of the cycle.

The cutting unit, with the blade **(1)**, includes the film coming out of the carriage and can also be installed after purchase of the machine.

During the last rotation, the roll holder carriage blocks the rollers and after the time set with **F27**, the machine stops, tightening the film, which is cut by the blade the number of times set with **F26**.

After cutting, the machine starts again, the carriage freely dispenses the film for a time set with **F28**, after which it blocks the rollers again, causing the film to break.

WARNING



The optional AUTOMATIC CUTTER and STRIP CUTTER cannot be installed on the machine at the same time; one installation excludes the other.

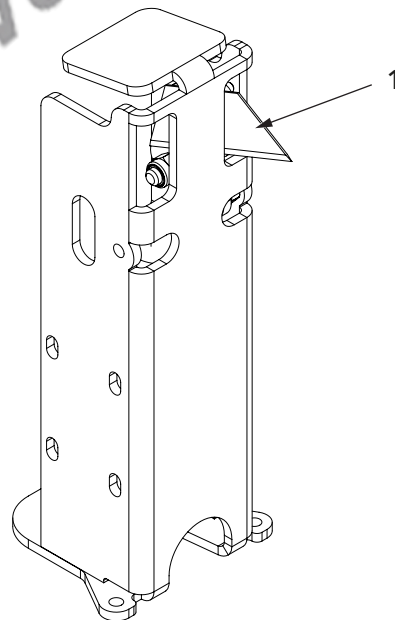

Picture 16

3.3.1.2 STRIP CUT

The strip cutting device can cut the film in 3, 4, or 5 strips, used to stabilize products that need air (e.g., flowers, fruit, etc.) using a common stretch film.

The frame **(1)** has 2, 3, or 4 blades **(2)** that cut the film in the position of the convex wheels **(3)** that keep the stretch film strips separated.

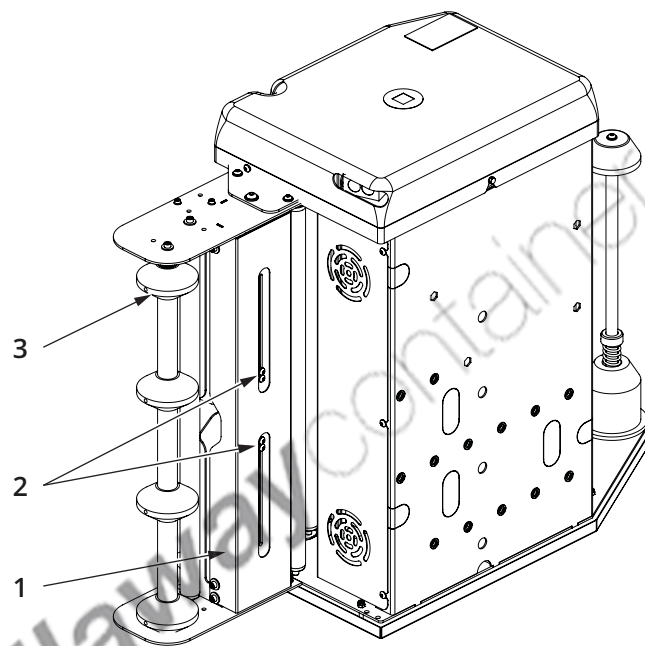

Picture 17

Using the functions that can be set from the control panel, it is possible to configure the wrapping cycle as follows:

F55 include (F55=1) or exclude (F55=0) strip cutting.

F56 delay insertion of the cut (F56=X seconds) at machine startup to being with an whole strip of film.

F57 and **F58** control the cut at the top of the product and exactly:

F57 delays the insertion of the cut (**F57** = X seconds) in descent startup if it was excluded with **F58** = 0.

F58 includes (**F58** = 1) or excludes (**F58** = 0) strip cutting during execution of the top reinforcement rotations.

F59 stops cutting during ascent and shutdown:

- ascending, an amount of time (**F59** = X seconds) after reaching the top of the product, cutting is disabled to move on to the entire strip.
- during shutdown, an amount of time (**F59** = X seconds) after the rotation starts to slow down, cutting is disabled, allowing the last segment of stretch film to exit unsectioned from the pre-stretch carriage for easier control.

If you want to wrap the top part of the product by overflowing the film beyond the top of the product itself, it is recommended to do so with the stretch film not cut into strips, the stretch film must be one entire strip; so, set **F58** = **0** and **F57** = X.

If, on the other hand, you do not want to overflow the top, it is also possible to cut the film into strips during the reinforcement rotations at the top, including cutting during this phase (**F58** = **1**).

WARNING



The optional AUTOMATIC CUTTER and STRIP CUTTER cannot be installed on the machine at the same time; one installation excludes the other.

3.3.1.3 STRIP TIGHTENER (MANUAL VERSION)

The manual strip tightener **(1)** reduces the width of the film to one string and reinforces binding of the product. It can also be installed later, attaching it as in the image below.

The device is comprised of a frame **(2)** in which the grooved wheel **(4)** slides, with the help of a lever **(3)**, reducing the width of the stretch film.

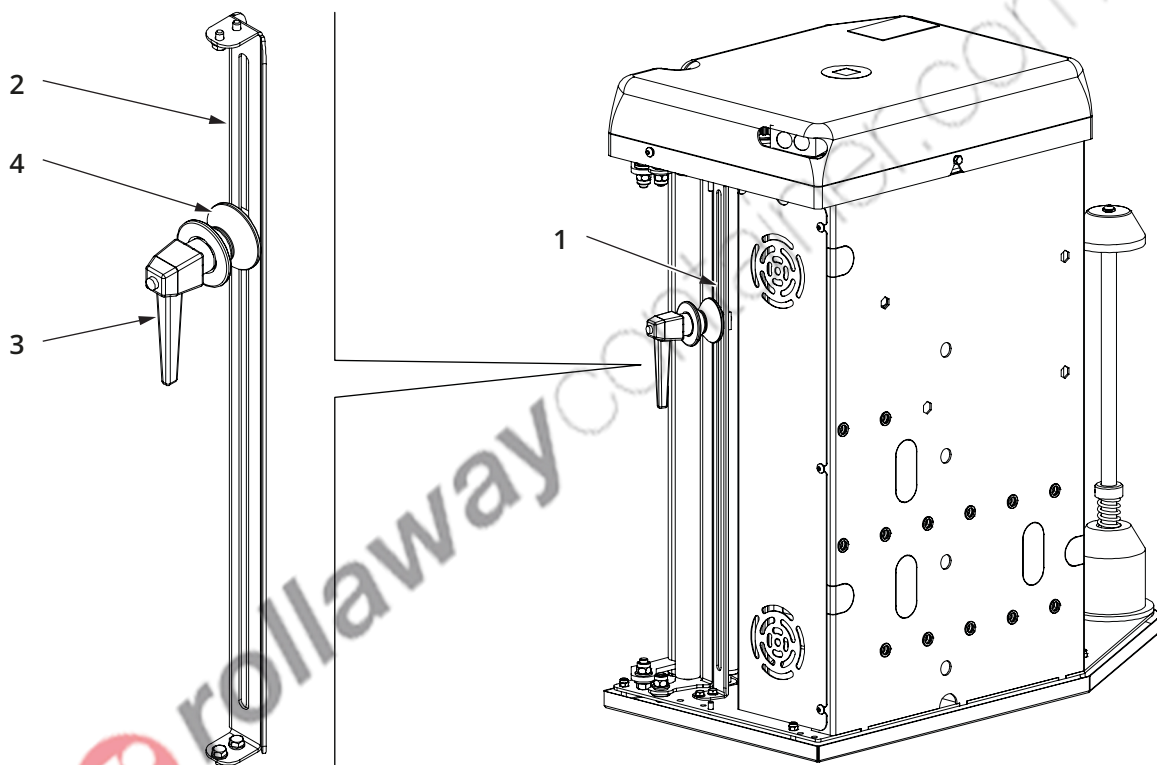

Picture 18

3.3.1.4 STRIP TIGHTENER (AUTOMATIC VERSION)

The automatic strip tightener reduces the width of the film to one string and reinforces binding of the product.

SINGLE AUTOMATIC STRIP TIGHTENER

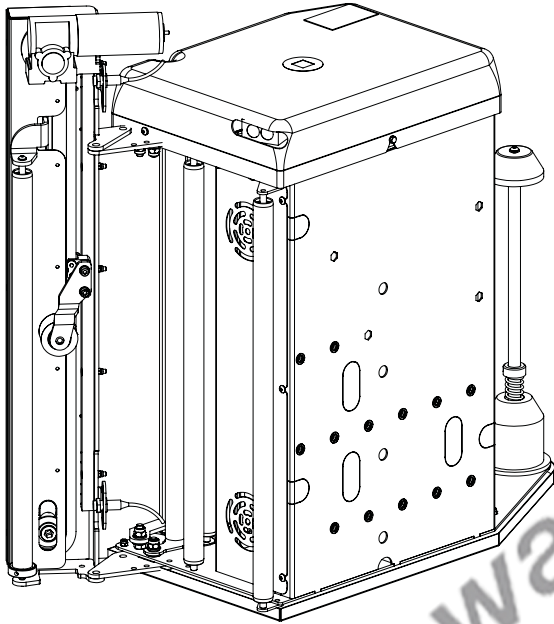

DOUBLE AUTOMATIC STRIP TIGHTENER

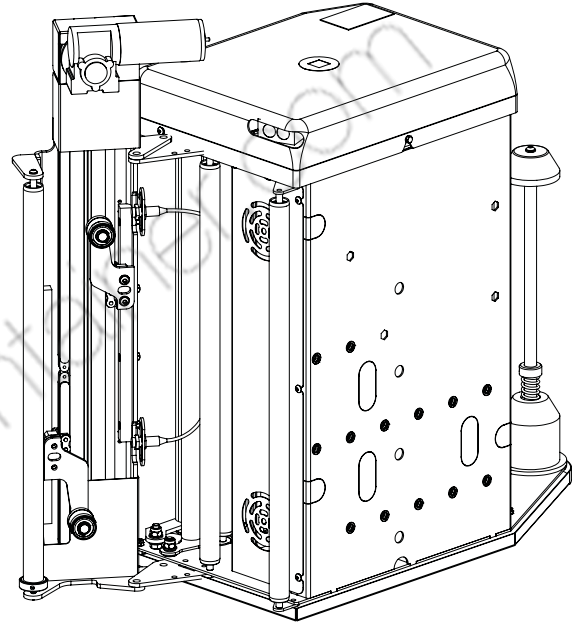

Picture 19

The device is made up of a frame (1) with a chain ring (2) controlled by a gear motor (3). The same frame has an idle roller (4) that forces the film to follow a certain path; see diagram (A). Attached to the chain (2) is a grooved idle wheel (6) (or two in the case of a double strip tightener).

Operating the gear motor (3), the chain (2) moves the grooved idle wheel (6) (or the two wheels in the case of the double strip tightener) vertically. When it encounters the strip of stretch film, it reduces the film width to a string.

The frame (1) has two sensors:

- sensor (7) stops the grooved wheel (6) in the bottom position that corresponds to the strip of stretch film reduced to a string.
- sensor (8) stops the grooved wheel (6) in the top position that corresponds to the extended strip of stretch film.

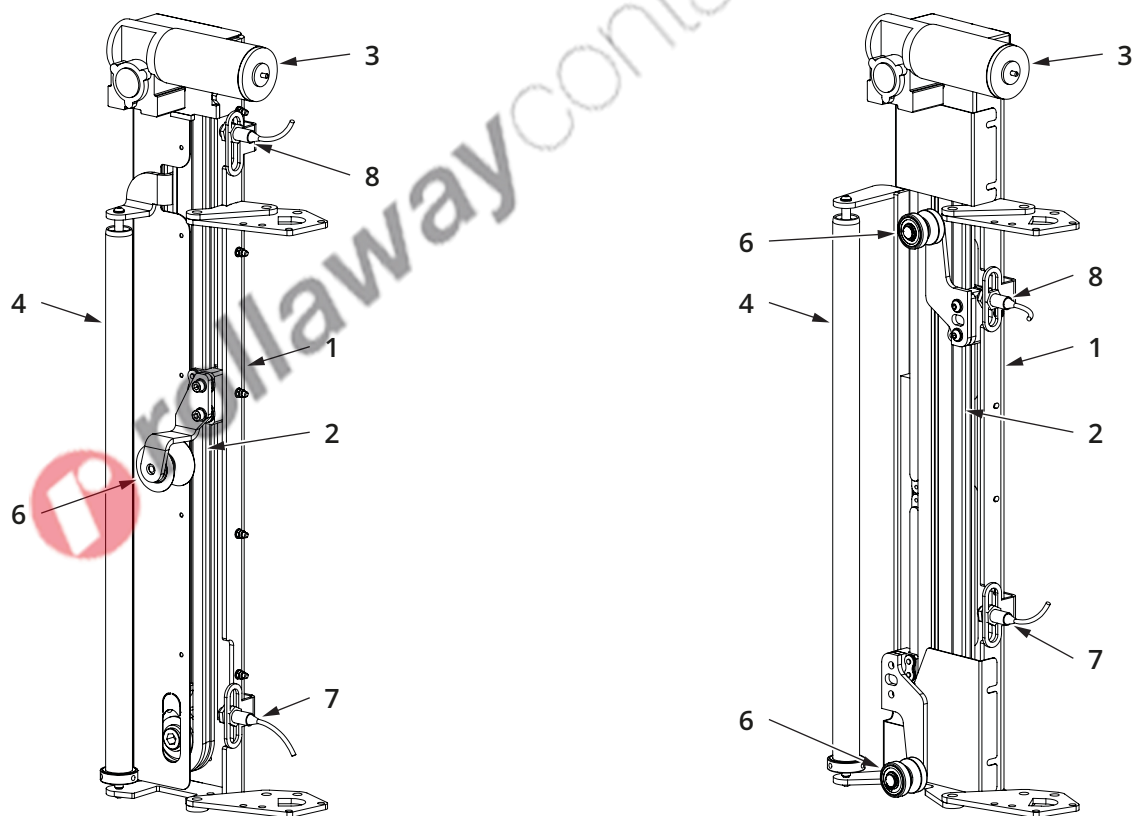

Picture 20

Open the door and insert the film between the rollers following the path indicated in figure (A), the symbol with the triangles identifies the side of the film to which the bonding agent (if present) is applied.

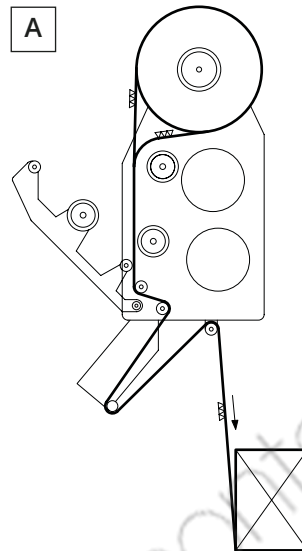

Picture 21

Using the functions that can be set from the panel, the following is possible:

- Exclude (**F34=0**) or include the device and choose the number of rotations **X** at the base of the product (**F34=X**).
- Exclude (**F36=0**) or include the device and choose the number of rotations **X** at the top of the product (**F36=X**).
- Exclude (**F35=0**) or include the device during carriage ascent (**F35=1** for the entire ascent, **F35=2** up to the reinforcement* excluded, **F35=3** from the reinforcement to the upper rotations and **F35=4** only during reinforcement*).
- Exclude (**F37=0**) or include the device (**F37=1**) during carriage descent.
- Choose the final number of bottom rotations (**F38=X**).
- Choose the reduction of the film strip, setting the adjustment time (**F39=X**).
- Enable the ascent of the carriage with the device included at the top of the product after performing the upper rotations with film open (**F63=X**).

(*) reinforcement set with **F7** and **F8**.

3.3.1.5 MESH ROLLER

The mesh roller allows the products to be wrapped using rolls of polyethylene mesh (1).

This material is highly indicated for wrapping products that need ventilation. Ventilation is ensured even with a high number of layers necessary to ensure product stability.

The mesh roller keeps the mesh tight between the product and the roll, without stretching it.

The optional mesh roller is comprised of a roll holder shaft (2) with a braking system plus a roller (3) with a special external finish, both of which are mounted in place of the standard ones.

The roll holder shaft (2) brakes the rotation of the roll (1) to ensure greater grip of the roller (3) on the mesh. The braked roller, grips the links of the mesh and tightens it towards the product.

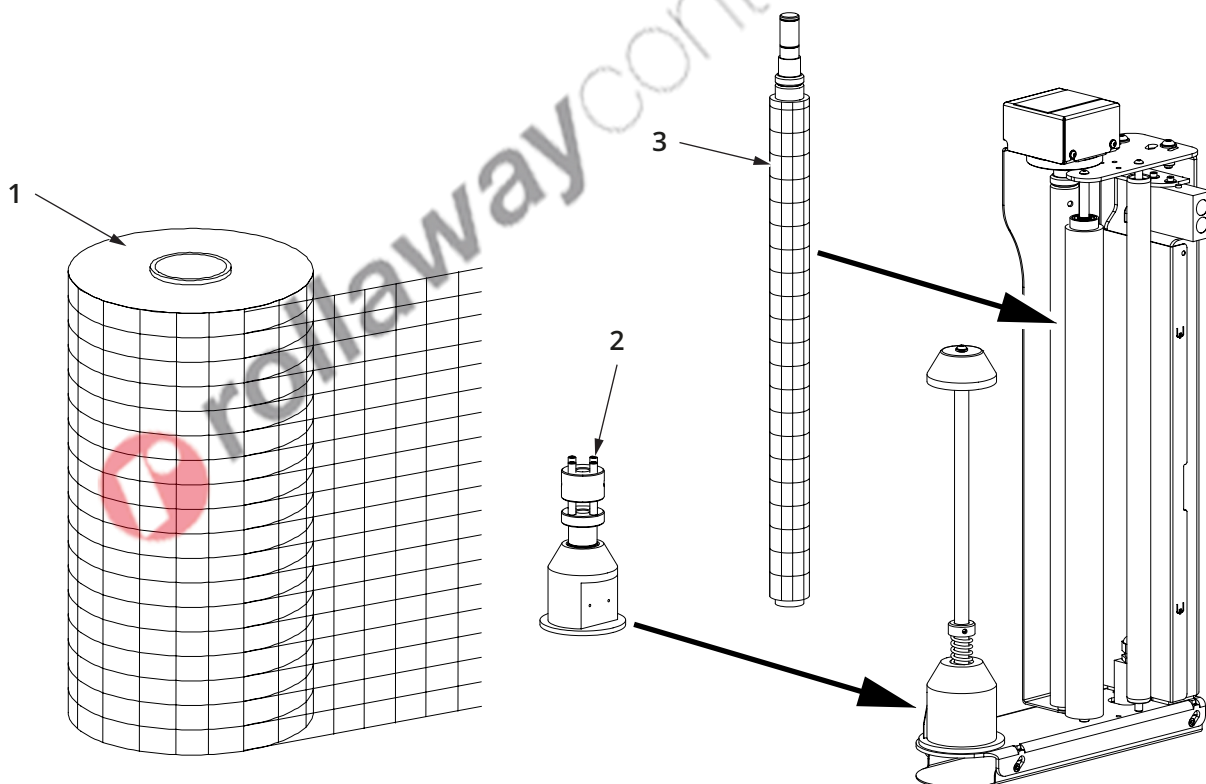

Picture 22

3.3.1.6 FILM WEIGHING

Film weighing calculates the amount of stretch film used to wrap each product, which is expressed in grams or metres.

At the end of each cycle, the machine will indicate the film consumption, showing "LF" on the screen (F) (if expressed in metres) or WF (if expressed in grams) and the quantity of metres or grams on the screen (V).

INFORMATION



If the weight is expressed in grams, to obtain good precision, correctly set the thickness of the film in microns (from 8 to 40) in the parameter F24.



Picture 23

3.4 INTENDED USE - PROPER USE - PURPOSE

The wrapping machine, designed to be anchored to the ground, has been designed and constructed for wrapping various types of products stacked on pallets of any shape and weight with stretch film, in order to stabilise the package and to protect it from damp and dust during transport and storage.

The wrapping operation is achieved by the machine rotating clockwise around the pallet, at a more or less constant distance guaranteed by a feeler wheel.

Working limitations

The machine is suitable for use in industrial, artisan and commercial environments.

For safety reasons appropriate limits of use are set: the minimum dimensions of the product that can be wrapped are given in Fig., while the maximum height of the product that can be wrapped depends on the height of the machine.

Stretch film

Use a film of specification suitable for the type of carriage available and for the type of packaging application for which the machine was intended; always evaluate the choice of film in relation to its safety sheet.

Use a perforated film if the wrapped products require ventilation otherwise they will generate condensation (fresh organic products: fruit, vegetables, plants, etc...).

Use a blackout film for the protection of light-sensitive products.

Use an antistatic film to prevent static electricity.

Min. dimension of the product to be wrapped (mm)

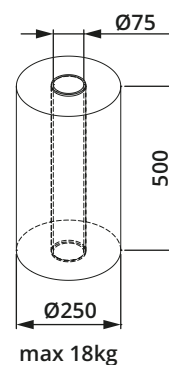
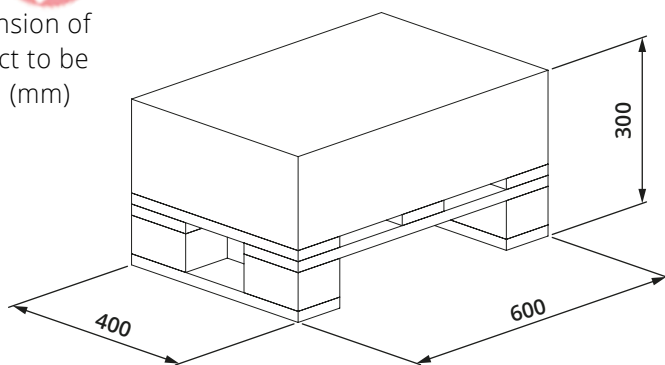

Roll film dimensions

Picture 24

3.5 UNINTENDED AND UNAUTHORISED USE - FORESEEABLE AND UNFORESEEABLE IMPROPER USE

Use of the pallet wrapping machine for unauthorised purposes, its improper use and lack of maintenance can lead to the risk of serious danger to health and safety of operators and exposed persons, as well as affecting the working efficiency and safety of the machine.

The following is a list of some possible, reasonably more foreseeable, examples of "bad usage" of the machine.

- NEVER climb onto the machine or use it to carry persons or objects.
- NEVER start the work cycle when there is anyone in the immediate vicinity of the machine.
- NEVER allow the machine to be used by unauthorised persons or by minors under the age of 16.
- NEVER use the machine for wrapping toxic, corrosive, explosive or flammable products.
- NEVER use the machine on ground with a slope of more than 2% or with a rough surface.
- NEVER use the machine near to ladders, ramps or the unprotected borders of floors .
- NEVER use the machine in places where there is the risk of fire or explosion.
- NEVER use the machine outdoors, on boats or on truck beds, or in unsuitable atmospheric conditions.

3.6 TECHNICAL DATA AND NOISE

• Overall dimensions	See Picture 25 - pag. 38
• Net weight of machine body	350 kg
• Battery voltage	24 V DC
• Battery current	90 - 100 Ah
• Stretch film	16/27 μ m
• Roll-holder tube inside \varnothing	75 mm
• Roll height	500 mm
• Maximum roll weight	18 kg
• Carriage speed	1 ÷ 4 m/min
• Max. wrapping speed	90 m/min.
• Max. wrapping height	2200 / 2700/3000 mm

Technical data of the built-in battery charger

• Power supply	230 V AC (std) / 115 V AC (Opt.)
• Supply frequency	50 / 60 Hz
• Phases	1+N/PE
• Nominal current	2.3 A (std) / 4.5 A (Opt.)

Noise

In observance of annex 1 of machine directive 2006/42/EC, the manufacturer declares that the noise emitted by the machine in question falls within the limits established by the above mentioned regulations 70 dB(A).

	A	B	C
H = 2200 mm	2320	2200	2070
H = 2700 mm	2820	2700	2570
H = 3000 mm	3120	3000	2870

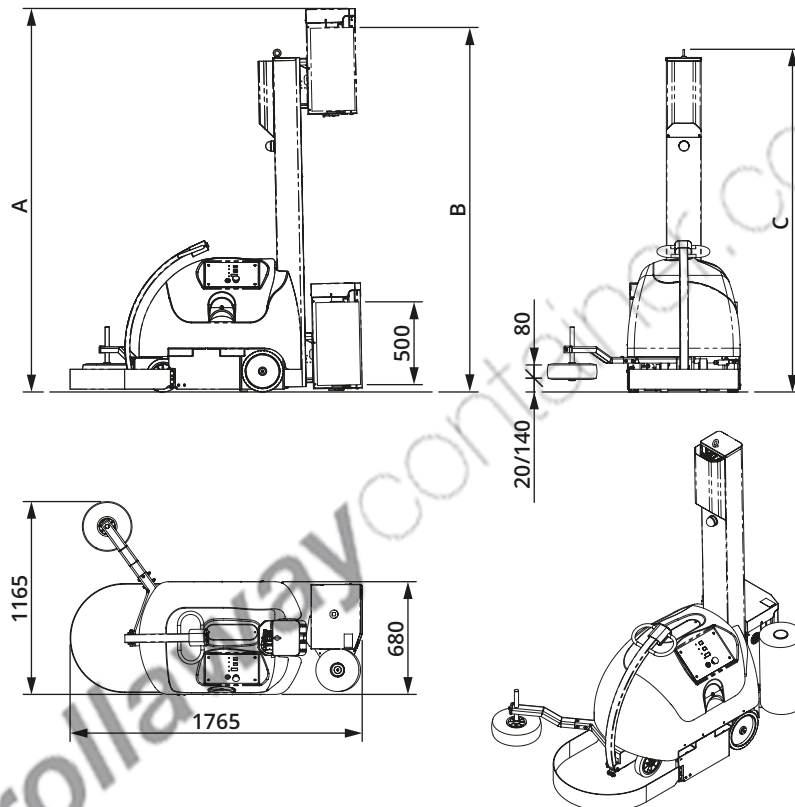

Picture 25

» See Picture 26 - pag. 39

3.7 WORK AND CONTROL STATIONS

AREA A - The machine work area extends to a perimeter distance of 1.5 m from the package.

Work area **(A)** inside which the machine operates to wrap the products must remain free of all obstructions. During the automatic work cycle access to this area is prohibited to other people.

Only the operator may approach this area solely to stop the machine.

The operator may access this area when the machine is stopped for maintenance, cutting, attaching and changing film and all the programming and start up procedures.

DANGER

Attaching and cutting film must be carried out with the machine stopped in the cycle paused condition. See the chapter on 'Starting up the machine' for details on starting and stopping the machine.

AREA B - The surveillance area extends to a perimeter distance of 3.5 m from the package.

The surveillance area (**B**) is for operators only and must be occupied by them to monitor the automatic work cycle.

AREA C - The free movement one is the area beyond 3.5 m from the package

The free movement area (**C**) has no presence or transit restrictions to other people even when the machine is working.

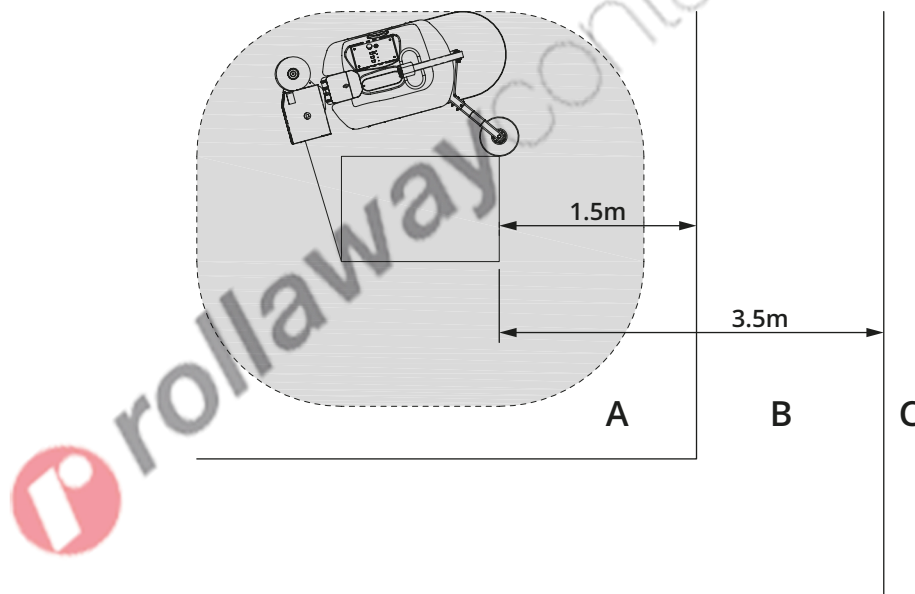

Picture 26

4 TRANSPORT-HANDLING-STORAGE

4.1 PACKING AND UNPACKING

The machine may be shipped in different ways depending on the transport requirements:

- Machine on a wooden pallet and protected by transparent plastic wrapping.
- Machine packed in a wooden crate of suitable dimensions.
- Machine on wooden base and protected by a cage of wooden crossbars.

Upon receipt, check that the packaging has not been damaged during transport or that it has not been tampered with and parts removed. Move the packed machine as close as possible to the place of installation and start unpacking, carefully checking that the supply corresponds to the order specifications.

DANGER



The lifting and transport means must be chosen based on the size, weight and shape of the machine and its components. The capacity of the lifting equipment must be greater (with a safety margin) than the weight of the components to be transported.

N.B.: If damaged or missing parts are found, immediately notify Customer Service and the carrier, providing photographic documentation.

Make sure that no small parts are left in the packaging.

Make a detailed examination of the general conditions of the machine.

The various packing materials must be disposed of in accordance with current environmental protection regulations.

WARNING



During unloading and handling operations, an assistant must be on hand to give any necessary directions during transport.

WARNING



THE MANUFACTURER declines all responsibility for damage caused by incorrect operations, unqualified personnel or the use of unsuitable means.

4.2 TRANSPORTING AND HANDLING THE PACKED MACHINE

WARNING



EXCLUSIVELY use a forklift truck of adequate capacity to lift and transport the **PACKED** machine. **USING ANY OTHER SYSTEM WILL NULLIFY THE WARRANTY FOR ANY DAMAGE CAUSED TO THE MACHINE.**

INFORMATION



THE WEIGHT OF THE PACKAGING IS GENERALLY INDICATED ON THE OUTSIDE.

DANGER



ALWAYS CHECK BEFORE ANY OPERATION THAT THERE ARE NO EXPOSED PERSONS IN HAZARDOUS ZONES (IN THIS CASE THE ENTIRE ZONE AROUND THE MACHINE PARTS IS TO BE CONSIDERED A HAZARDOUS ZONE).

Insert the forks of the lift truck where shown by the arrows (See Picture 27 - pag. 41).

Package dimensions:
1535x790x2200 mm

Package weight:
400 kg

* STD machine

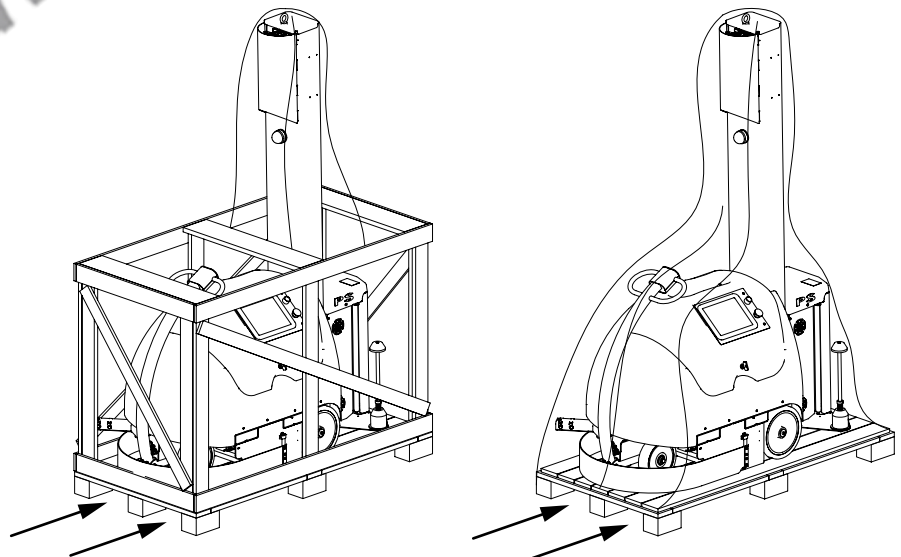

Picture 27

4.3 TRANSPORTING AND HANDLING THE UNPACKED MACHINE

» See Picture 28 - pag. 43

- Free the machine from the packaging as shown in the figure.
- Carefully insert the forks of the forklift into the rails **(A)**, marked with the pictogram **(B)**, to the maximum possible depth.
- Lift and transfer the machine to the installation location.

WARNING



EXCLUSIVELY USE A FORKLIFT TRUCK OF ADEQUATE CAPACITY TO LIFT AND TRANSPORT THE MACHINE. USING ANY OTHER SYSTEM WILL NULLIFY THE WARRANTY FOR ANY DAMAGE CAUSED TO THE MACHINE.

DANGER



THE RISK OF IMPACT IN ANY CASE REMAINS, CAUSED BY SUDDEN MOVEMENT DUE TO UNBALANCING OF THE MACHINE PARTS IN THE EVENT THAT THE BELTS SAG OR SLIP. LIFT THE MACHINE SLOWLY AND SMOOTHLY (WITHOUT JERKING OR PULSES).

DANGER



ALWAYS CHECK, BEFORE ANY OPERATION, THAT THERE ARE NO EXPOSED PERSONS IN HAZARDOUS ZONES (IN THIS CASE THE ENTIRE ZONE SURROUNDING THE PALLETS IS TO BE CONSIDERED AS A HAZARDOUS ZONE).

To lift the machine, proceed as follows:

- Carefully insert the forks of the forklift into the rails **(A)**, marked with the pictogram **(B)**, to the maximum possible depth.
- Lift and transport the machine.

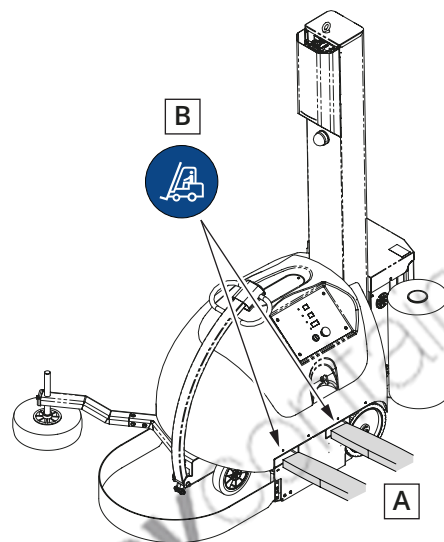

Net Weight: 350 kg

Picture 28

4.4 STORAGE OF PACKED AND UNPACKED MACHINE

In the event of long periods of inactivity, the customer must check the place where the machine is positioned and depending on the type of packaging (crate, container, etc.), ensure that the storage conditions are suitable.

If the machine is not used and stored in a place according to the technical specifications, the sliding parts must be greased.

Special attention must be paid to the drive batteries. It is important to disconnect them during periods of inactivity by unplugging the battery power supply connector and they should be recharged every two months.

In case of doubt, contact Customer Service.

5 INSTALLATION

5.1 PERMITTED AMBIENT CONDITIONS

Atmospheric conditions:

The machine is able to function correctly in atmospheric conditions with relative humidity no greater than 50% at a temperature of 40°C and 90% at a temperature no greater than 20°C (without condensation). If the atmospheric conditions are not suitable for machine operation, the Manufacturer can, on request, provide solutions to remedy the problem (e.g. air conditioners, thermostatic heating elements, etc.).

DANGER



The standard machine is not designed or set up for operation in places with an explosive atmosphere or risk of fire.

Flooring:

The machine must be used inside a room that has the following flooring requirements:

- slope less than 2%,
- no ladders or floor borders which could cause the machine to tip over,
- even ground with no holes, dips, rises, obstructions or discontinuities,
- conductive flooring which allows the static electricity built up to be discharged.

5.2 FITTING THE UNITS

» See Picture 29 - pag. 45

Any operations that need to be carried out with some of the safety devices disabled, must be performed by a MECHANICAL MAINTENANCE TECHNICIAN OR A SPECIALISED TECHNICIAN. These operations must be carried out by one person only.

DANGER



DURING ALL MAINTENANCE, REPAIR OR ADJUSTMENT OPERATIONS, THE EMERGENCY MUSHROOM BUTTON ON THE CONTROL PANEL MUST ALWAYS BE ACTIVATED AND THE BATTERY DISCONNECTED.

For transport purposes, some units may be disassembled; to reassemble them, proceed as described below.

Safety bumper unit:

Undo the screws **(1)**, fit the bumper unit **(2)** as shown in the drawing and then screw the screws **(1)** back in through the holes **(3)**.

Feeler wheel unit:

Undo the screws **(4)**, fit the wheel unit **(5)** as shown in the drawing and then screw the screws **(4)** back in, securing them with the relative nuts as shown in the illustration.

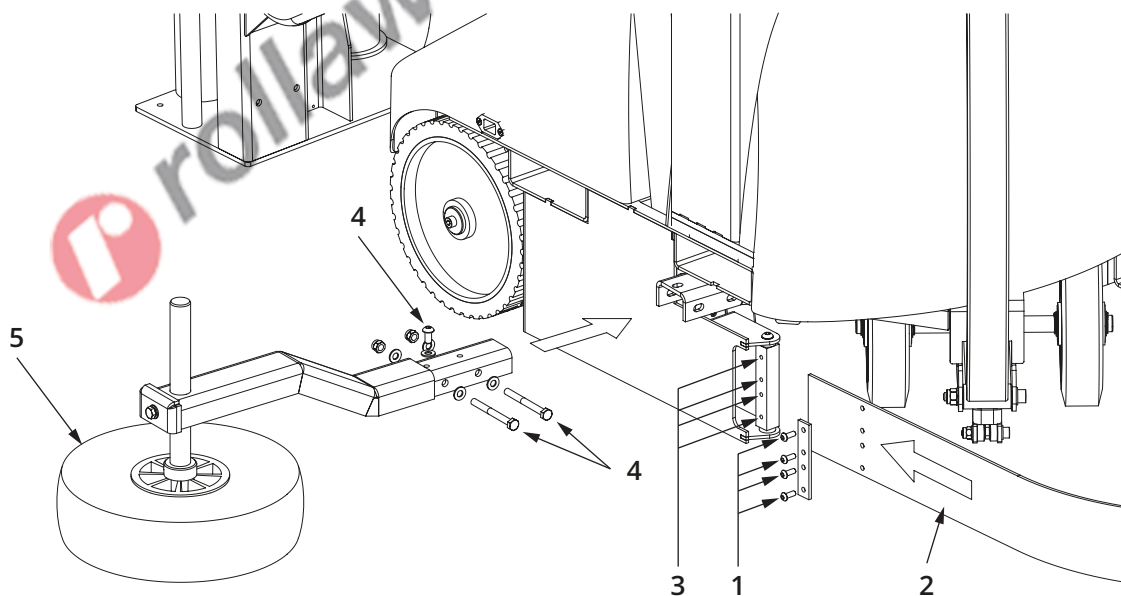

Picture 29

» See Picture 30 - pag. 47

Repositioning the base column

A) Identify the supplied screws for fixing the base column;

DANGER



The lifting of the column should be carried out using a suitable lifting device (1), fixed to the eyebolt on the column.

B) lift the base column (2);

C) bringing the column (2) the basement (3);

D) enter the column (2) in the 'opening of the crankcase (4) as shown;

E) put in the support column (2) the basement (3), screw the 4 screws (5) inside the casing and the two nuts (6) at the bottom;

F) unhook the column;

G) connect the plug (7) into socket (8).

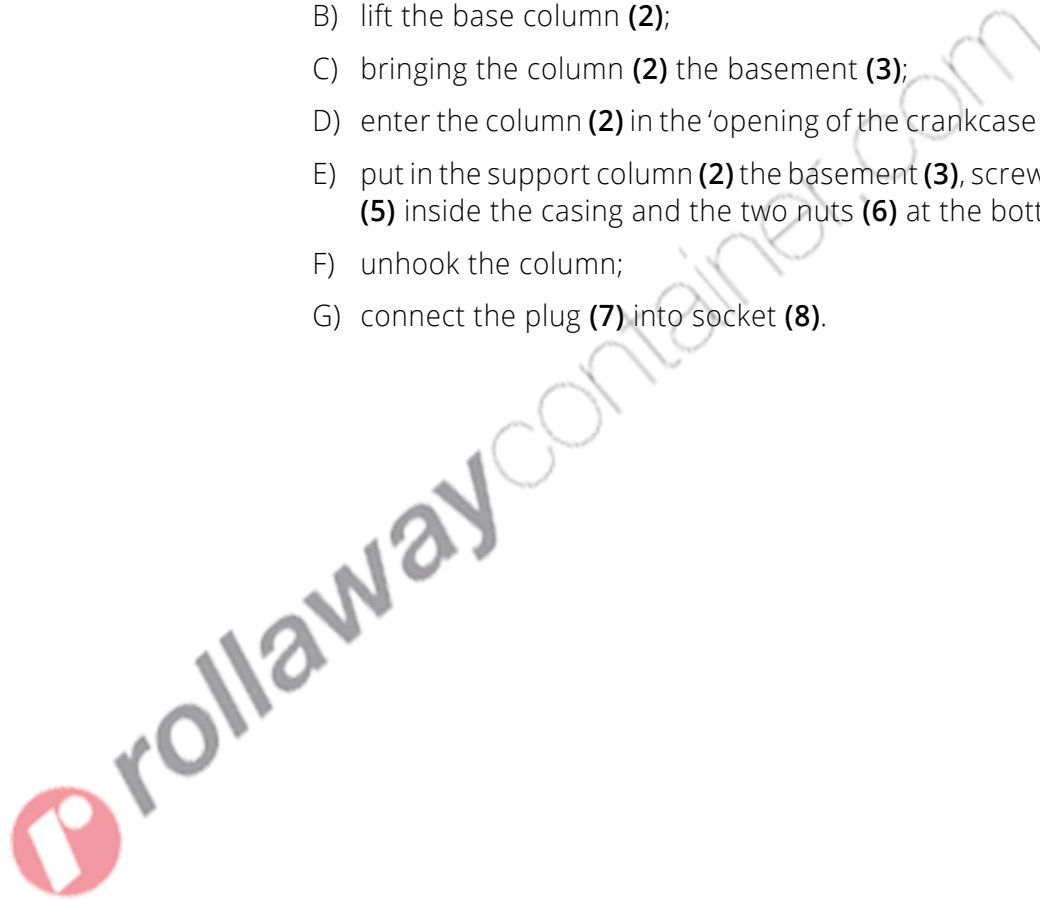

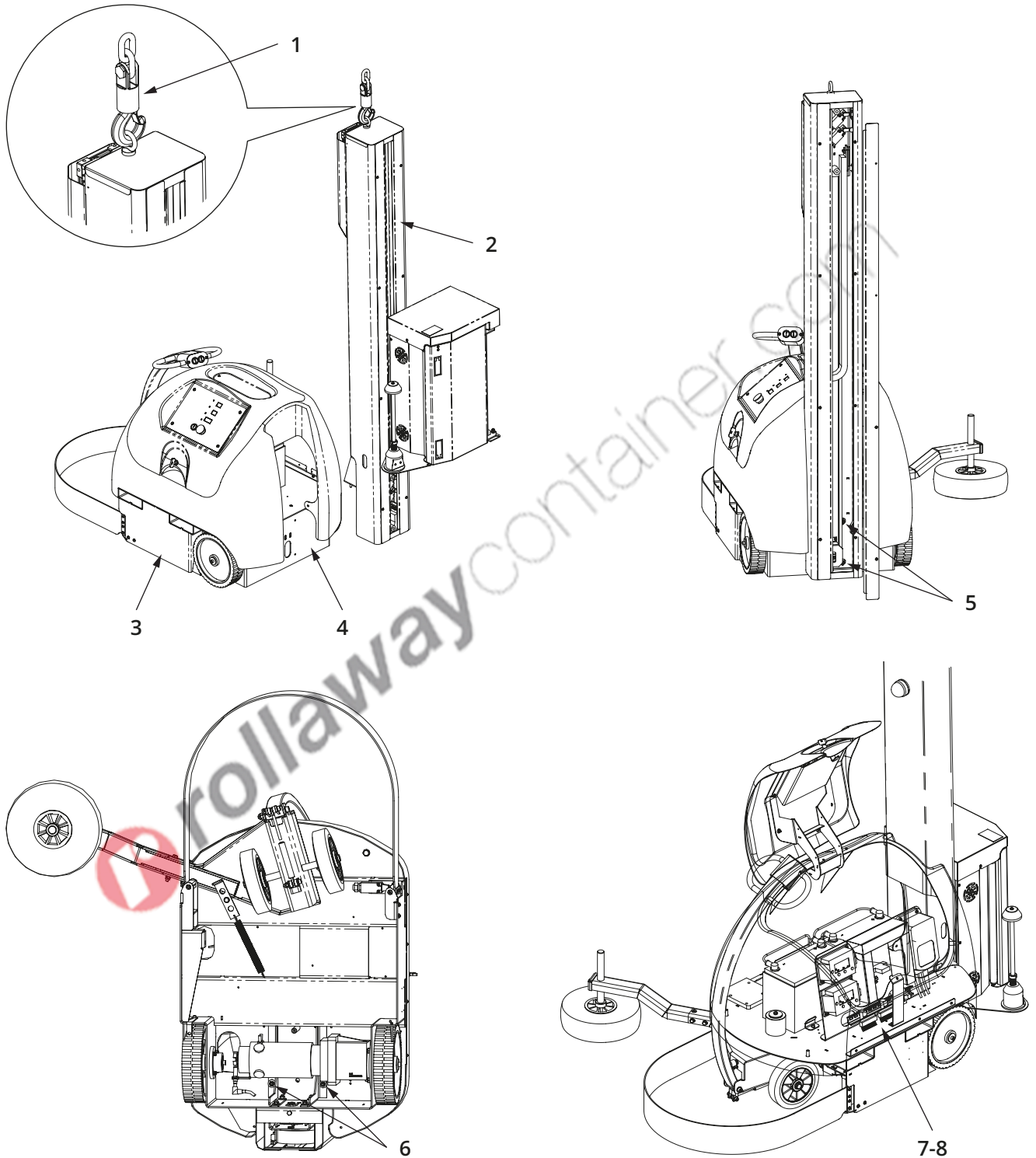

Picture 30

6 STARTING UP THE MACHINE

6.1 ELECTRICAL PANEL

1) Control panel

It allows programs to be used and wrapping parameters set in a simple and practical manner.

INFORMATION



For further information, consult the Operator Panel Manual attached.

2) Reset button

Provides power to the auxiliary circuits, has to be pressed to switch on or after the emergency button has been pressed.

3) Programmed cycle START button

4) Emergency button

Stop the machine and cuts off the main power supply in situations of emergency or imminent danger; to reset the button once it has been pressed, turn the top of the button clockwise.

5) Movement Controls, par. "6.2.3" pag. 51.

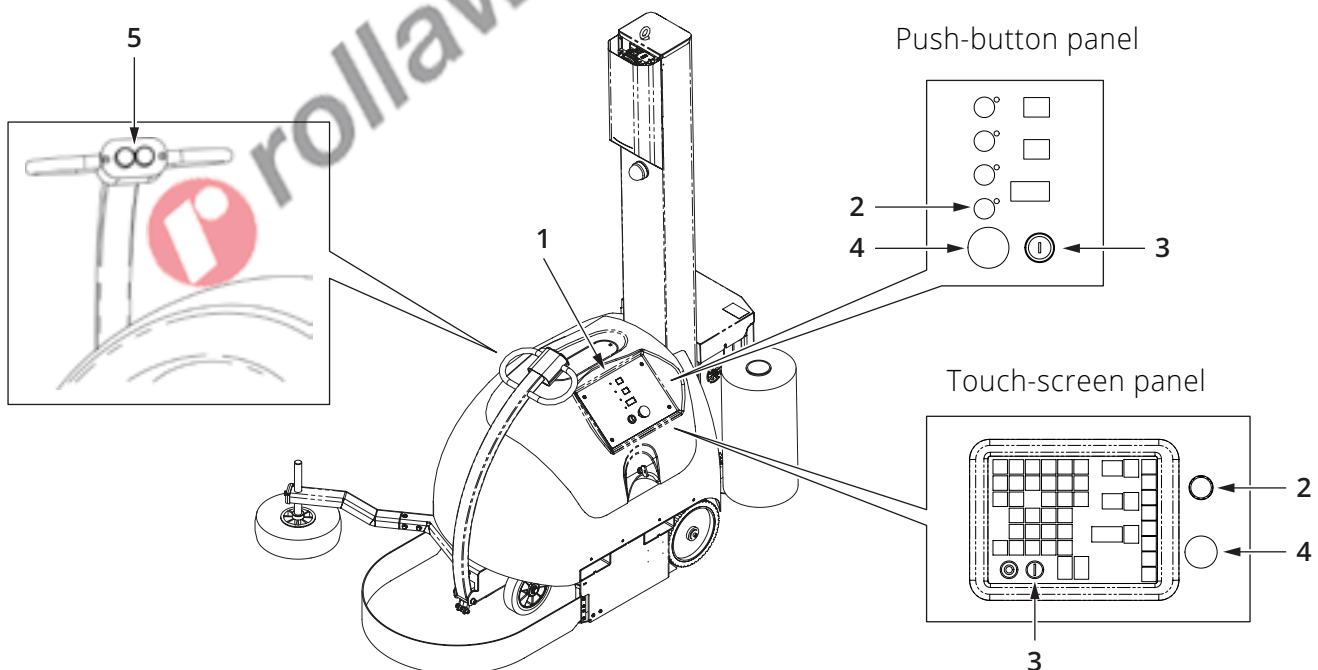

Picture 31

6.2 INSTRUCTIONS FOR USE

6.2.1 LOADING A ROLL OF FILM

» See Picture 32 - pag. 49

This is a general procedure.

Carriage-specific operations are described in the relative roll-holder carriage manual.

- A) Lower the roll-holder carriage **(1)** to make it easier to load the roll;
- B) press the emergency button **(2)** in order to work in safety;
- C) open the carriage door (depending on the carriage model);
- D) push the roll **(3)** onto the carriage pin **(4)**;
- E) unwrap the film and thread it between the rollers;
- F) close the carriage door.

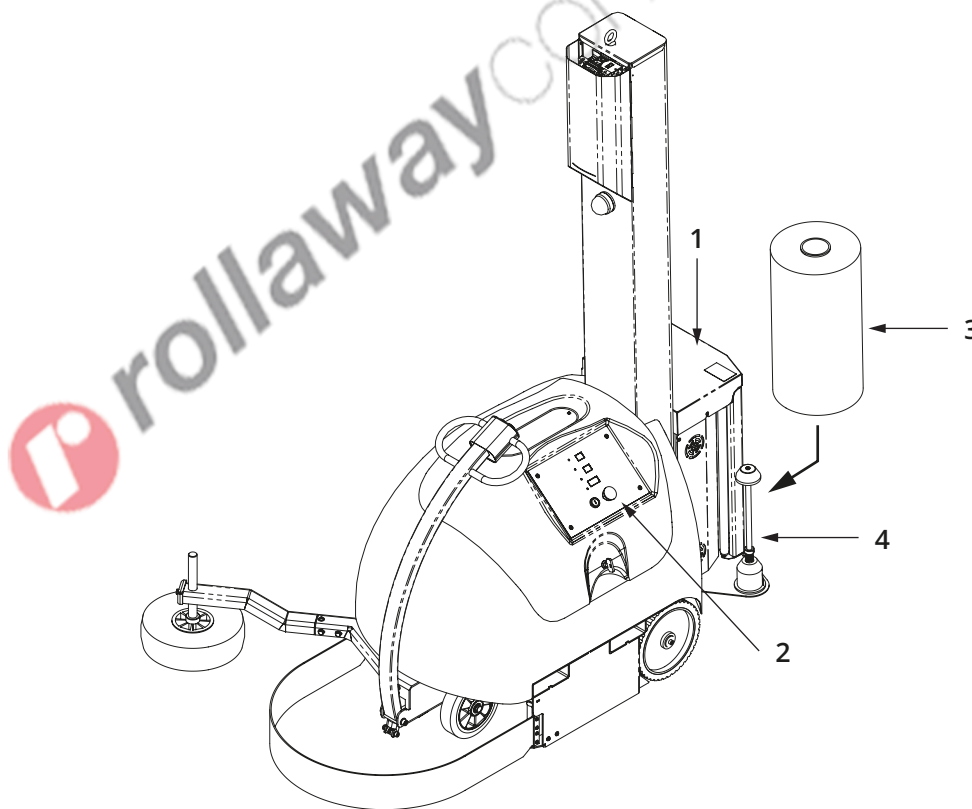

Picture 32

6.2.2 STARTING THE MACHINE

DANGER



BEFORE STARTING THE WORK CYCLE MAKE SURE THAT THE AREA AND THE GROUND AROUND THE PRODUCT TO BE WRAPPED ARE FREE OF ALL OBSTRUCTIONS AND THAT NO OBJECTS HAVE BEEN LEFT ON THE MACHINE.

WARNING



AFTER STARTING THE CYCLE, THE OPERATOR MUST MOVE AWAY FROM THE MACHINE WORK AREA IMMEDIATELY.

» See Picture 33 - pag. 50

- A) Prepare the machine for the work cycle, release the emergency button (if it is pressed in) and then press the RESET button;
- B) after placing the pallet with the product to be wrapped in the work area, bring the machine up to it using the manually controlled steering arm **(1)**, pressing the forward movement buttons **(2)**;
- C) place the feeler wheel **(3)** up against one side of the pallet;
- D) manually draw out the film protruding from the roll-holder carriage **(4)** and attach it to one corner of the pallet;
- E) set the operating cycle from the control panel;
- F) press the START;
- G) after wrapping, manually cut the film and fix it to the pallet;
- H) the pallet can now be picked up.

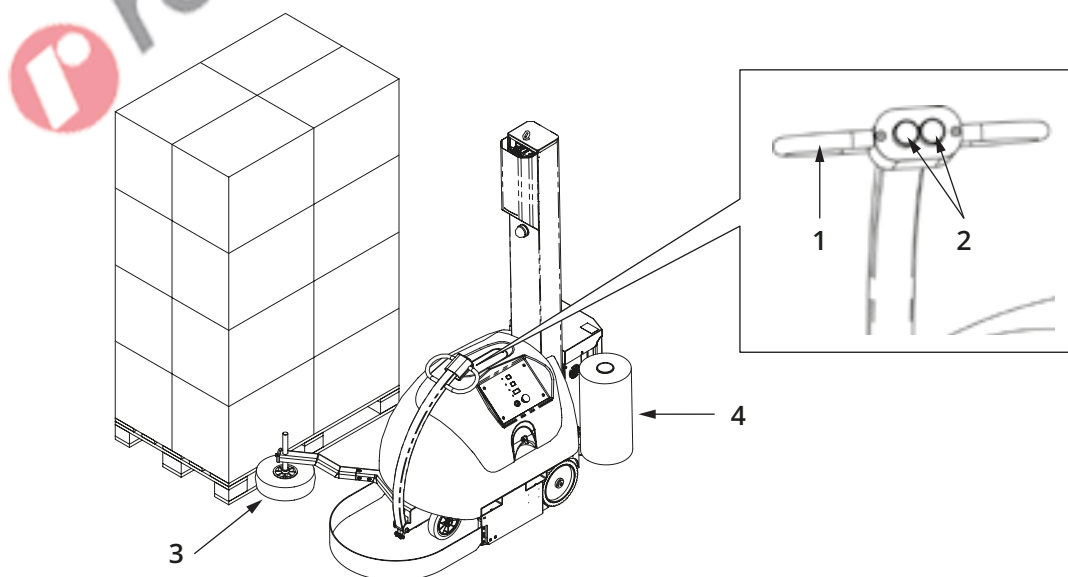

Picture 33

6.2.3 MANUAL MACHINE MOVEMENT

DANGER



THE MACHINE CAN ONLY BE STEERED MANUALLY WITH THE CARRIAGE IN THE FULLY LOWERED POSITION AND ON FLOORING WITH A SLOPE OF LESS THAN 10°.

» See Picture 34 - pag. 51

The machine can be moved automatically for short movements inside the workplace. It is moved by the operator using the steering arm (1) and the movement controls (2).

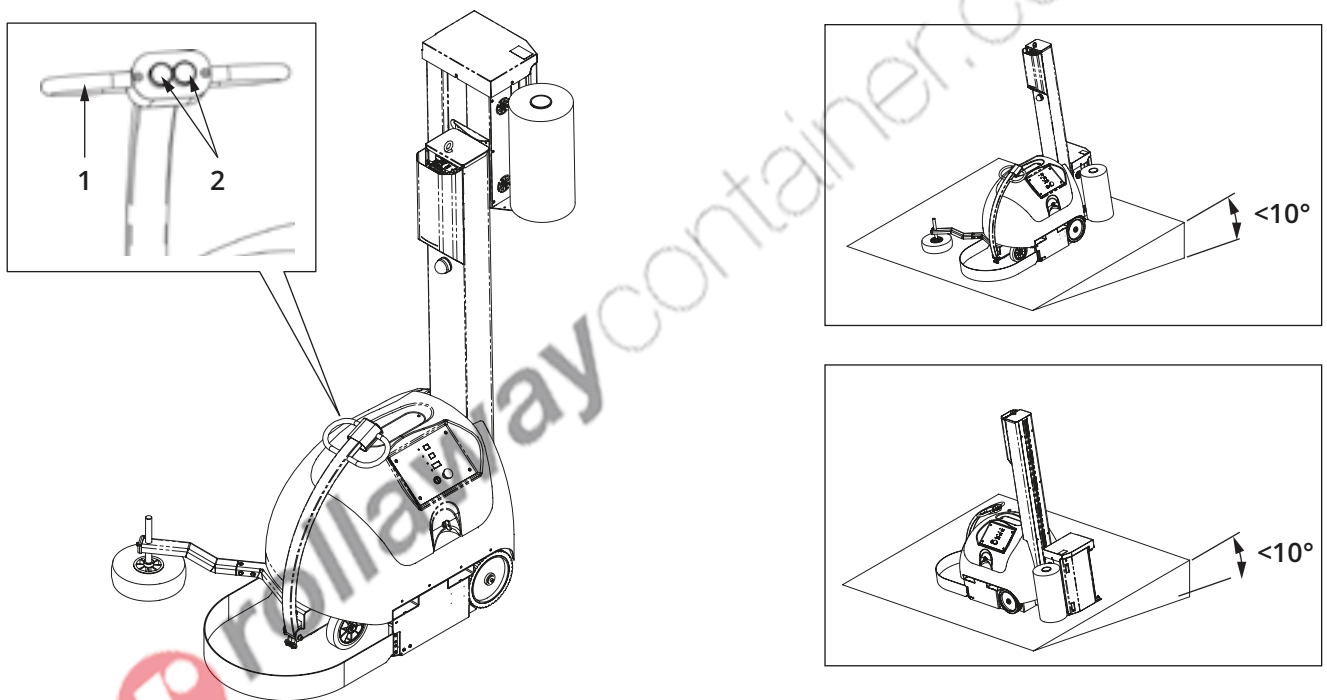

Picture 34

6.2.4 CYCLE STOP

Press STOP (O) on the operator terminal to stop machine at the end of its current cycle.

6.2.5 STOPPING THE MACHINE AFTER USE

» See Picture 35 - pag. 52

After using the machine, even for short periods of inactivity, it must be put into the safe mode.

- A) lower the carriage **(2)** down to the ground;
- B) switch off the machine by pressing the emergency button **(1)**.

6.2.6 EMERGENCY STOP

» See Picture 35 - pag. 52

The machine is equipped with an emergency pushbutton **(1)**.

Pressing the pushbutton, the machine will stop immediately. To restart the machine it is necessary to turn the pushbutton to rearm and press the RESET button to reactivate the control panel.

DANGER



THE MOTOR IS FITTED WITH A SYSTEM THAT GUARANTEES AN IMMEDIATE STOP, HOWEVER ON PARTICULARLY SMOOTH OR SLIPPERY FLOORING THE MACHINE MAY TAKE LONGER TO STOP.

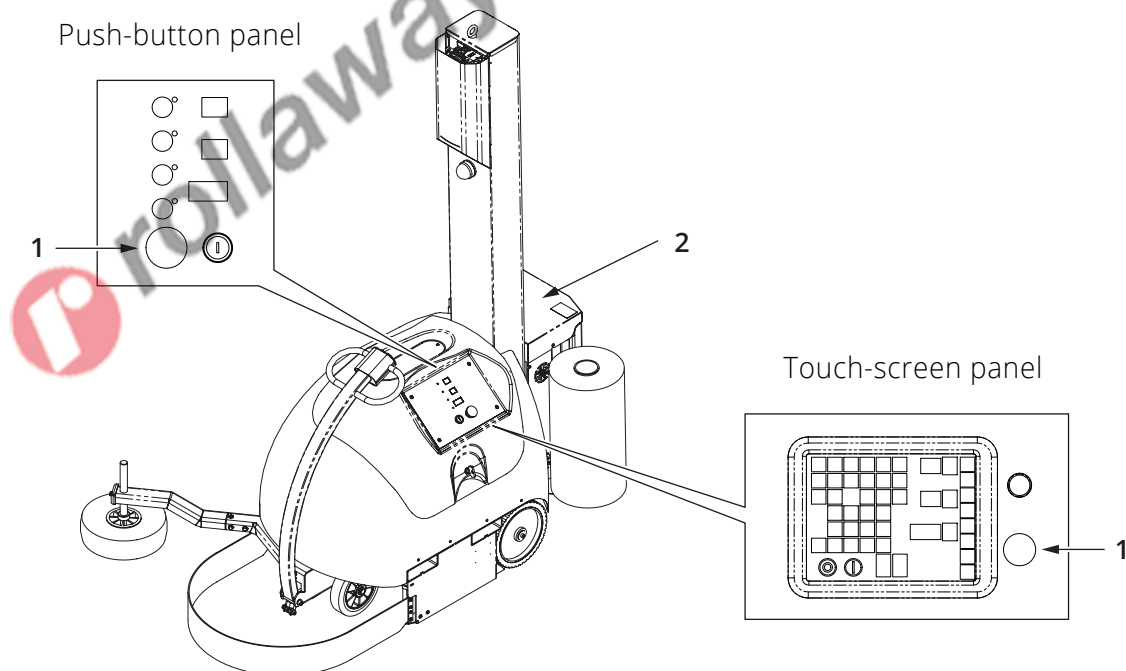

Picture 35

6.3 ADJUSTMENTS

6.3.1 PRODUCT READING ARM ADJUSTMENT

DANGER



DURING ALL MAINTENANCE, REPAIR OR ADJUSTMENT OPERATIONS, THE EMERGENCY MUSHROOM BUTTON ON THE CONTROL PANEL MUST ALWAYS BE ACTIVATED AND THE BATTERY DISCONNECTED.

» See Picture 36 - pag. 53

The reading arm, on which the wheel that follows the outline of the product to be wrapped is mounted, is subject to two adjustments:

A) Wheel height

Undo screw **(1)**, raise or lower wheel pin **(2)** as shown in the drawing, position the wheel so that it runs around the pallet without depressions and/or protrusions, then tighten screw **(1)**.

B) Steering force

The arm steering or closure is controlled by a spring **(3)** coupled to a bracket **(4)** secured to the steering arm.

The bracket **(4)** can be set in different positions **(5)** to adjust the spring tension.

To change the position, release the bracket **(4)** pulling it by the tab **(6)** and reset it in the desired position.

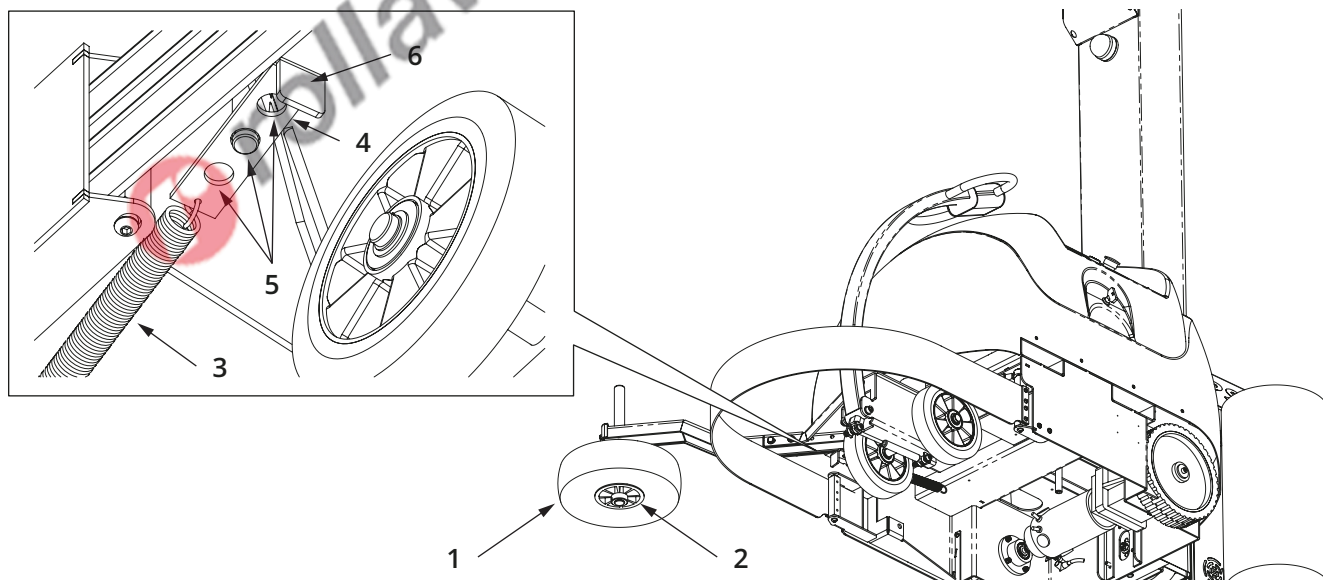

Picture 36

A more rigid spring results in:

- Greater steering force.
- Greater steering arm rigidity during manual movements.
- The risk of lightweight pallets moving on slippery flooring.

A less rigid spring results in:

- Reduced steering force.
- Reduced steering arm rigidity during manual movements.
- The risk that the robot does not correctly follow the outline of the pallet during high-speed wrapping.

6.3.2 SAFETY SYSTEMS EFFICIENCY CHECK

This section contains a description of the actions the operator must take to test the efficiency of the safety systems, before starting up production.

DANGER



THIS PROCEDURE CAN BE OPERATED ONLY BY A GRADE 2 QUALIFIED MAINTENANCE ENGINEER.



rollaway

6.3.3 EMERGENCY BUTTONS OPERATIONAL CHECK

With the machine running, press the emergency pushbutton **(A)**. Check that the machine comes to an immediate halt. Release the previously pressed emergency pushbutton and press the ENABLE MACHINE pushbutton. Press START to restart the machine.

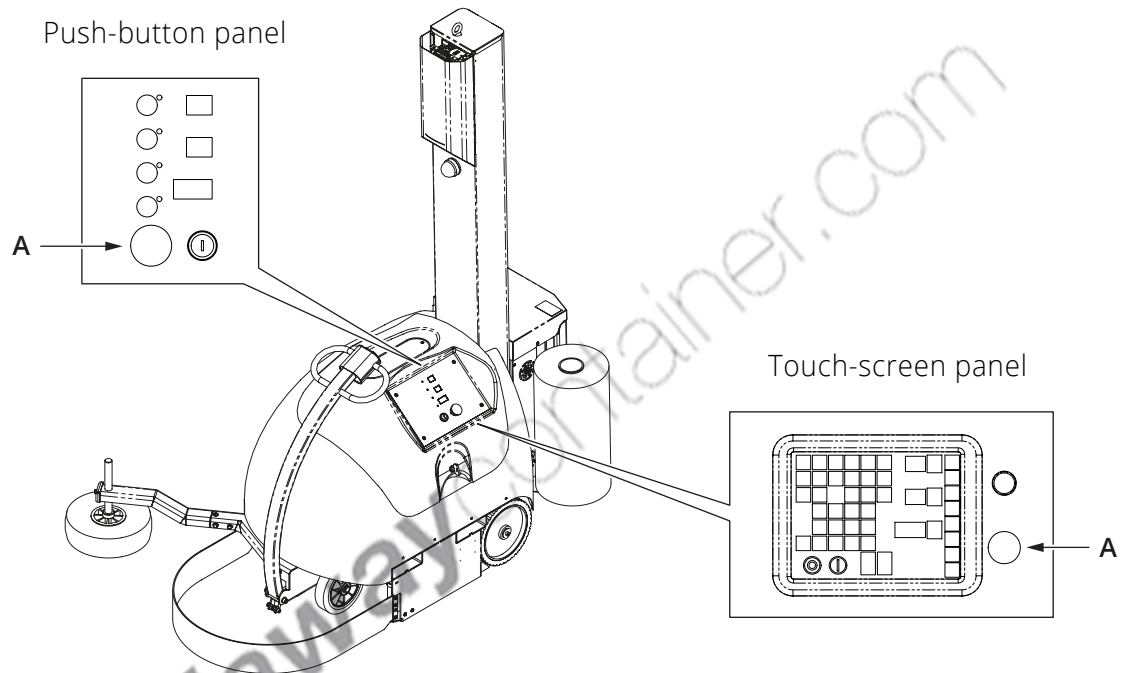

Picture 37

7 MAINTENANCE

7.1 GENERAL PRECAUTIONS

DANGER



Maintenance personnel must act in accordance with the instructions contained in this document and strictly observing the accident prevention regulations set forth by international directives and by the legislation of the country where the machine will be installed.

Additionally, PPE suitable for all maintenance operations must be worn.

WARNING



Maintenance operations that require acting on mechanical parts and/or electrical components must be carried out by qualified technicians.

The operator can only clean and visually check the instruments of the machine.

INFORMATION



All maintenance information refers exclusively to routine maintenance procedures and to works aimed at ensuring that the machine operates correctly on a daily basis. Supplementary maintenance procedures must be carried out by the Manufacturer's specialised technicians.

- Provide sufficient lighting when servicing the machine. If maintenance involves areas that are poorly illuminated, portable lighting devices must be used. Make sure to avoid causing dark cones that prevent or reduce the visibility of the point on which you are going to work or of the surrounding areas.
- Use only original materials when repairing the machine in order to ensure the safety of the machine in any case. The tools available must be suitable for the task to be done. Never use any tool or equipment for a purpose other than that for which they were made.

7.1.1 MACHINE DISCONNECTION

Before performing any maintenance or repair operations, disconnect the machine from all the power sources.

Make sure that the battery charger is not connected to the mains supply and unplug the batteries.

7.1.2 SPECIAL PRECAUTIONS

When performing maintenance or repair operations, observe the following:

- Before starting work, post a sign "MACHINE UNDER MAINTENANCE" in a well visible position.
- Do not use solvents or flammable materials.
- Take care not to pollute the environment with cooling lubricants.
- Use suitable equipment to access the upper parts of the machine.
- Do not climb onto machine components or guards, as they have not been designed to support the weight of a person.
- After completing the maintenance operations, refit and properly secure all the protection devices and safety guards that have been removed or opened.

7.1.3 CLEANING

Periodically clean the safety guards, particularly the transparent material of the casing, using a damp cloth.

7.2 SCHEDULED MAINTENANCE

This paragraph describes the operations to be carried out periodically in order to ensure proper functioning of the machine.

WARNING



IT IS ESSENTIAL TO SCRUPULOUSLY OBSERVE THE MAINTENANCE OPERATIONS DESCRIBED BELOW IN ORDER TO MAKE THE MACHINE MORE EFFICIENT AND ENSURE A LONGER LIFE.

INFORMATION



IF MACHINE MAINTENANCE IS NOT CARRIED OUT IN COMPLIANCE WITH THE INSTRUCTIONS PROVIDED, THE MANUFACTURER DECLINES ALL RESPONSIBILITY FOR MACHINE MALFUNCTIONS.

WARNING



AFTER ANY WORK CARRIED OUT INSIDE THE CENTRE COMPARTMENT OF THE MACHINE, MAKE SURE THAT NO OBJECTS OR TOOLS HAVE BEEN LEFT INSIDE AND PUT THE CAPS BACK ON THE BATTERY TERMINALS.

7.2.1 ACTIVE SAFETY DEVICES MAINTENANCE

DANGER



CHECK THE EFFICIENCY OF THE SAFETY DEVICES BEFORE STARTING WORK.

WHENEVER POSSIBLE:

Check that the safety bumper **(1)** works properly.

- A) Turn on the machine.
- B) Turn the emergency push-button to reset it.
- C) Press the reset button to reset any alarm indicators.
- D) Stay at the control position. Do not move to the operating position.
- E) Use your foot to press on the safety bumper until a 'click' is heard. This means that the limit stop is engaged. Tap on the reverse button on the steering arm.
- F) Repeat the procedure but this time press the forward motion button.
- G) The machine should not move in either case. The control panel should show an alarm.

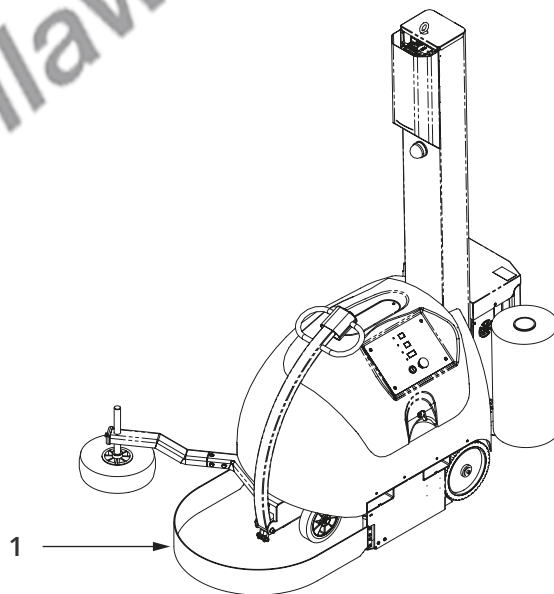

Picture 38

7.2.2 WEEKLY MAINTENANCE

Cleaning. Using only a cotton cloth dampened with hot water or isopropyl alcohol, thoroughly clean away all traces of dirt from the machine work and movement surfaces which could cause surface friction leading to problems in sliding over these surfaces.

» See Picture 40 - pag. 61

Turn off the machine and check the backlash of the roll-holder carriage. If the carriage **(1)** can be freely lifted by a few centimetres, the chain **(2)** must be tensioned as follows:

- Undo the nut **(3)**, tighten the screw **(4)** until the oscillation of the slack branch, measured at mid-height of the column **(5)** is within ~2 cm.
- Tighten the nut **(3)**.
- Lubricate the sliding surfaces **(2)** with grease.

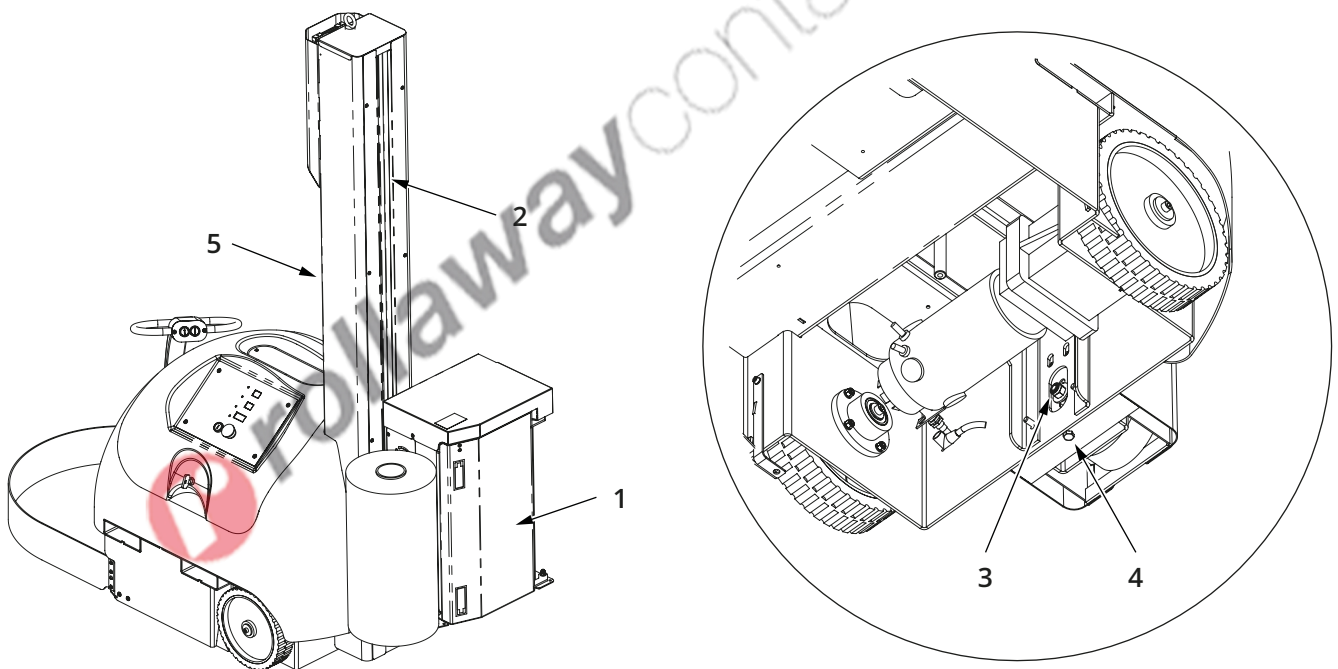

Picture 39

7.2.3 HALF-YEARLY MAINTENANCE

» See Picture 40 - pag. 61

Check that under rest conditions the arm moves fully to the end of travel (0).

If necessary, replace the control spring.

Check the state of wear of the front and rear wheels and the rubber-coated roller of the roll-holder carriage; if any worn parts are found they must be replaced by ordering original spare parts from Service Assistance.

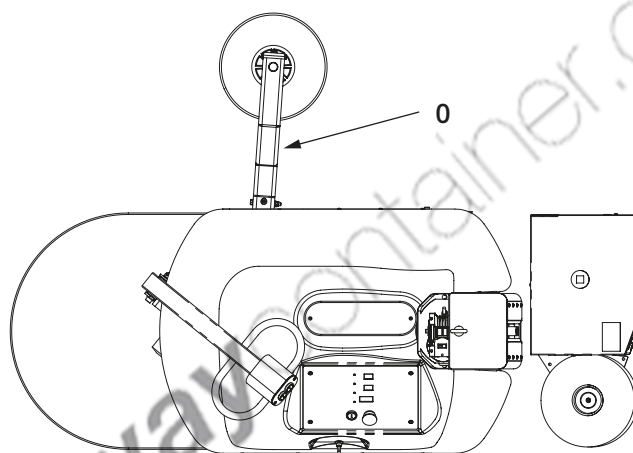

Picture 40

7.2.4 CHARGING THE BATTERY

DANGER



THE MACHINE USES A SEALED GAS RECOMBINATION BATTERY, REGULATED WITH A SAFETY VALVE MANUFACTURED USING AGM TECHNOLOGY WHICH GUARANTEES A HIGH LEVEL OF SAFETY IN USE. IT IS FORBIDDEN TO REPLACE THE BATTERY WITH ONE OF A DIFFERENT TYPE FROM THE ORIGINAL ONE FITTED.

WARNING



TO PROLONG THE LIFE OF THE BATTERIES, THE RECHARGING CYCLE MUST ALWAYS BE ALLOWED TO REACH THE END.

WARNING

TO PROLONG THE LIFE OF THE BATTERIES, DO NOT LEAVE THEM FOR MORE THAN TWO MONTHS WITHOUT RECHARGING; THE BATTERIES MUST ALSO BE RECHARGED DURING PERIODS OF EXTENDED MACHINE INACTIVITY.

The machine has two 12V batteries, connected in series and housed in the central compartment, accessible by raising the control panel door (1).

The battery supply cable (2) is located between the two accumulators and should be unplugged when carrying out maintenance or repairs inside the machine; the battery charger (3) is located on the base plate.

The battery lifetime depends on how well it is looked after, it is important that the battery is always kept charged. In periods when the machine remains inactive the batteries must be checked and recharged at least once every two due months.

DANGER

USE ONLY THE BATTERY CHARGER BUILT INTO THE MACHINE, SPECIFICALLY DESIGNED FOR THE BATTERIES FITTED. USING A DIFFERENT BATTERY CHARGER CAN CAUSE DAMAGE TO THE BATTERY AND THE RISK OF TOXIC SUBSTANCES BEING GIVEN OFF.

DANGER

FOR MORE INFORMATION ON USE AND MAINTENANCE OF THE BATTERIES AND BATTERY CHARGER, READ CAREFULLY THE INSTRUCTIONS ENCLOSED WITH THE MACHINE DOCUMENTS.

» See Picture 41 - pag. 63

Recharge the batteries when the signal lights up on the control panel, proceeding as follows.

- A) Bring the machine close to a socket and turn it on.
- B) Open the hatch **(1)**, pull out and extend the charging cable **(4)**.
- C) Plug the pin **(5)** into the power supply socket. Make sure that the cable is not very taut when you approach the machine to the socket.
- D) As soon as the pin is connected, the automatic charging starts. If there is a power failure or the batteries get disconnected (power supply connector of the batteries), the charging process is interrupted. Charging starts all over again once power is back.

For alerts or further information on the product, please refer to the specific manual **(6)** of the battery charger **(3)** that is attached to the documents.

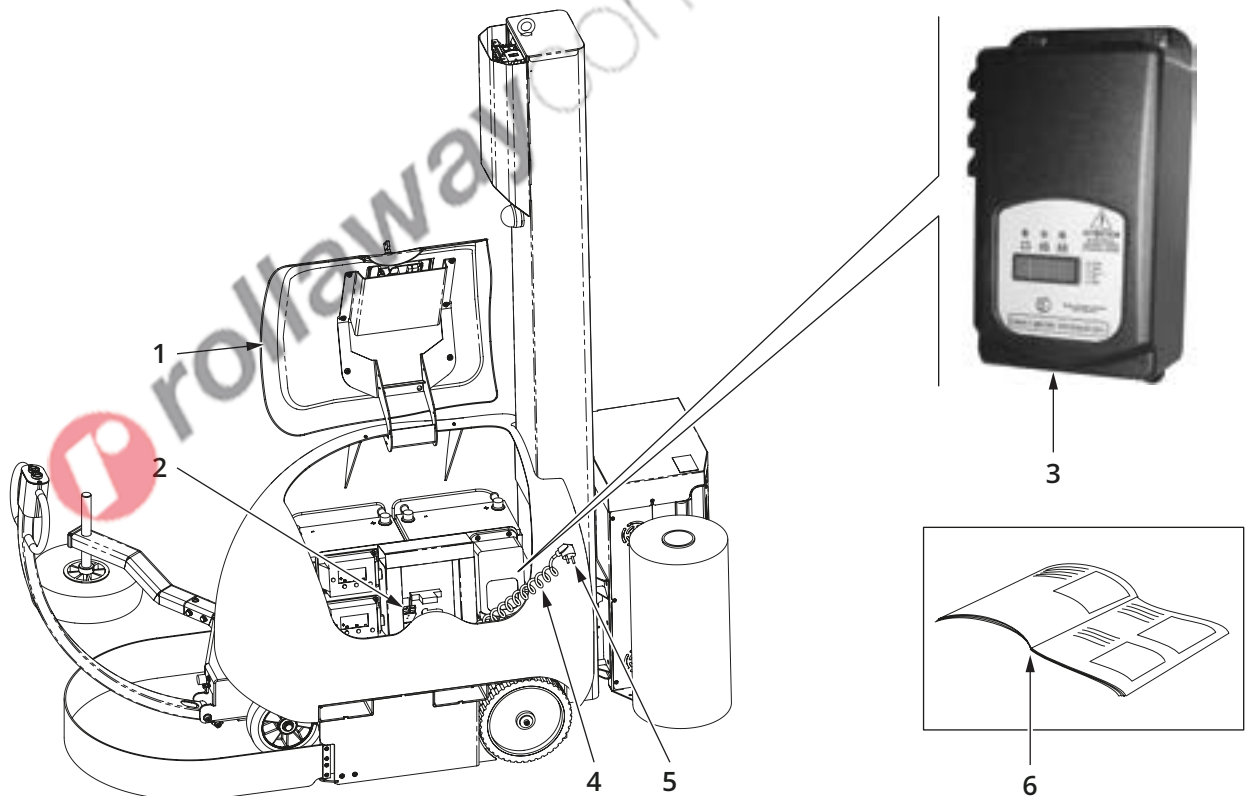

Picture 41

8 OUT OF SERVICE

8.1 DISMANTLING, SCRAPPING AND DISPOSAL

DANGER



IF THE MACHINE OR ITS COMPONENTS ARE FOUND TO BE NO LONGER SERVICEABLE OR REPAIRABLE BECAUSE THEY ARE BROKEN, WORN OR HAVE COME TO THE END OF THEIR WORKING LIFE, THEY MUST BE DEMOLISHED.

- Demolition must be carried out using suitable equipment, chosen on the basis of the type of material in question.
- All components must be dismantled and scrapped after being broken down into smaller parts, so that none of them can reasonably be used again.
- When the machine is scrapped, its parts must be disposed of in a differentiated manner, taking into account their different types (metal, oil and lubricants, plastic, rubber, etc..) handing them over to collection centres authorised for such purposes and in any case conforming to the applicable laws in force governing the disposal of solid industrial waste.

DANGER



NEVER TRY TO RE-USE MACHINE PARTS OR COMPONENTS THAT MAY STILL APPEAR INTACT ONCE THEY HAVE BEEN DECLARED NO LONGER SERVICEABLE.

DANGER



USED BATTERIES ARE A DANGER TO THE ENVIRONMENT. THEY MUST BE TAKEN TO A SUITABLE RECYCLING/DISPOSAL CENTRE, IT IS RECOMMENDED THAT USED BATTERIES BE CONSIGNED DIRECTLY TO THE SUPPLIER WHEN THE NEW BATTERIES ARE DELIVERED.

8.2 DISMANTLING ELECTRONIC PARTS (WEEE DIRECTIVE)



La direttiva comunitaria 2012/19/UE (RAEE), impone ai produttori e agli utilizzatori di apparecchiature elettriche ed elettroniche una serie di obblighi relativi alla raccolta, al trattamento, al recupero e allo smaltimento di tali rifiuti.

Si raccomanda di attenersi scrupolosamente a tali norme per lo smaltimento di tali rifiuti. Rammentare che lo smaltimento abusivo di tali rifiuti comporta l'applicazione delle sanzioni amministrative previste dalla normativa vigente.

 rollawaycontainer.com

 **rollaway**container.com

 **rollaway**container.com

 rollawaycontainer.com



Atlanta Stretch S.p.A.

Via Torriane, 58

47824 Poggio Torriana (RN) - ITALY

Tel. 0541 627145

www.atlantastretch.com

info@atlantastretch.com